

Railway Main Line Cables

DENMARK



Linking the Future

As the worldwide leader in the cable industry, Prysmian Group believes in the effective, efficient and sustainable supply of energy and information as a primary driver in the development of communities.

With this in mind, we provide major global organisations in many industries with best-in-class cable solutions, based on state-of-the-art technology.

Through two renowned commercial brands - Prysmian and Draka - based in almost 50 countries, we're constantly close to our customers, enabling them to further develop the world's energy and telecoms infrastructures and achieve sustainable and profitable growth.

For our energy business, we design, produce, distribute and install cables and systems for the transmission and distribution of power at low, medium, high and extra-high voltage.

For telecoms, the Group is a leading manufacturer of all types of copper and fibre cables, systems and accessories for voice, video and data transmission.

Drawing on over 130 years' experience and continuously investing in R&D, we apply excellence, understanding and integrity to everything we do, meeting and exceeding the needs of our customers across all continents - while at the same time shaping the evolution of our industry.





What links global expertise to the wheels of industry?

High-performing cable solutions to keep the wheels of industry turning

On every continent, in applications that range from rolling stock and vehicles for high-speed trains and urban mass transit lines, to all types of rail transport infrastructure, Prysmian's specialist cable solutions sit at the heart of significant international projects - supporting the work of major customers, with high-performing, durable and safe technology.

As the world leader in cabling, we draw on global expertise and local presence to work in close proximity with our customers in order to deliver product and service solutions built on workability, customized solutions and effective supply chain, that help them drive the wheels of industry and achieve sustainable growth and profitability.

Railway Main Line Cables

History of the railways

When George Stephenson's steam locomotive "The Rocket" emerged as the winner of the Rainhill Race in 1829, with an average speed of 12.5 mph = 20 km/h, no one could predict the triumphant progress the railways would make in the almost 200 year period that followed. Within just a few decades, the railway developed into a broadly integrated transport system, which drastically reduced travel times, and made it possible to develop infrastructure - especially in the New World on the continent of North America. The triumph of the railways began with a 330 km railway line, as early as 1830. Over the next fifty years, the industry grew exponentially and reached almost 370,000 km. Nowadays, the railway infrastructure extends to more than 1.1 million km.

With the advent of civil aviation, the railway lost its role as the main means of transport for middle and long distances, and has long been regarded as outdated, slow and uncomfortable. But in recent years, the railway has experienced a revival. With the introduction of electronic interlocking technology and agreement on a European system for the management and control of railway transport - ERTMS (European Rail Traffic Management System), the rail transport once again plays an important role especially over medium distances. Thanks to a variety of European and other internationally operating system providers in the field of interlocking technology, the ERTMS system, which originated in Europe, has been experiencing an explosive worldwide acceptance over the past few years.

Urbanisation

A major challenge for the railways as a means of mass transport, which is also an unparalleled opportunity, is represented by the increasing urbanisation of the world's population. In 2013, approximately 51% of the 7 billion people inhabiting the planet resided in an urban environment. By 2050, not only will the world's population have increased to approximately 9 billion people, but the proportion of people living in cities will have grown to about 70%. Thus, some 6.3 billion inhabitants will reside every day in large cities and be on the move. Car-bound private transport is destined to collapse and a change to rail-based transportation is therefore, without rival.

Tram and metro systems as well as regional trains and light rail vehicles will interconnect the cities into low-emission zones. Megacities are already in planning, such as the Chinese project "Turn The Pearl Delta Into One", in which nine cities with a total of 42 million people are to be merged into a single city. The most modern railway systems will form the backbone of this metropolis. A total of 29 lines with a network of altogether 1500 km will service the region and allow transit times of maximum one hour from one end of town to the other.

Percentage of urban population and agglomerations by size, class 1980

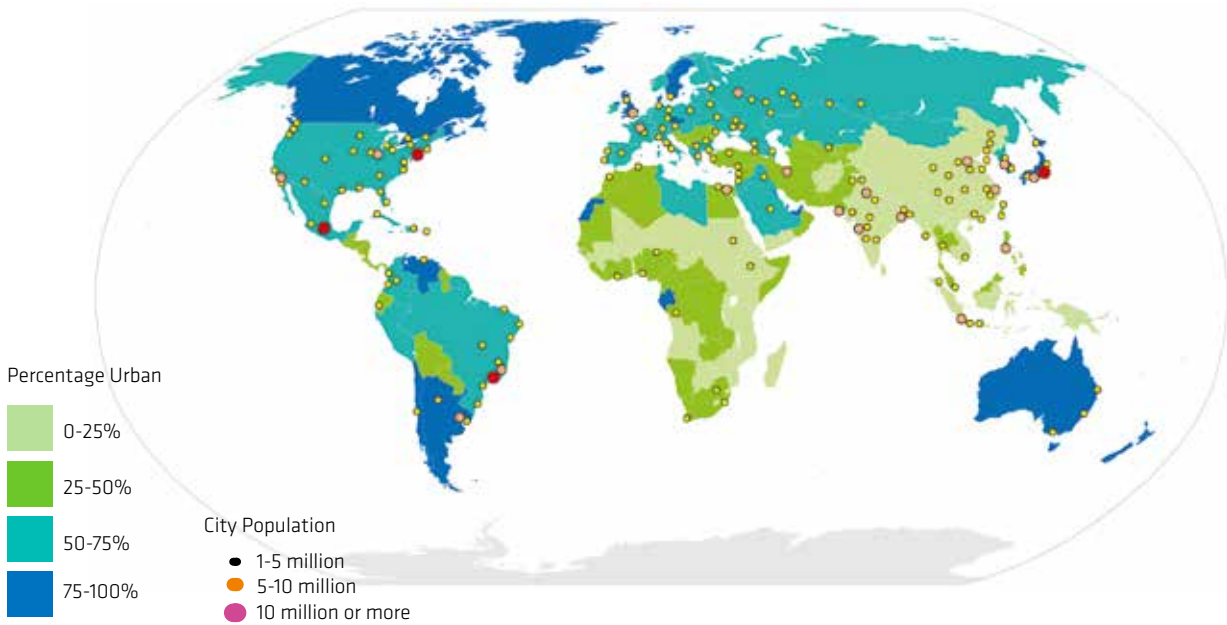

Percentage of urban population and agglomerations by size, class 2025

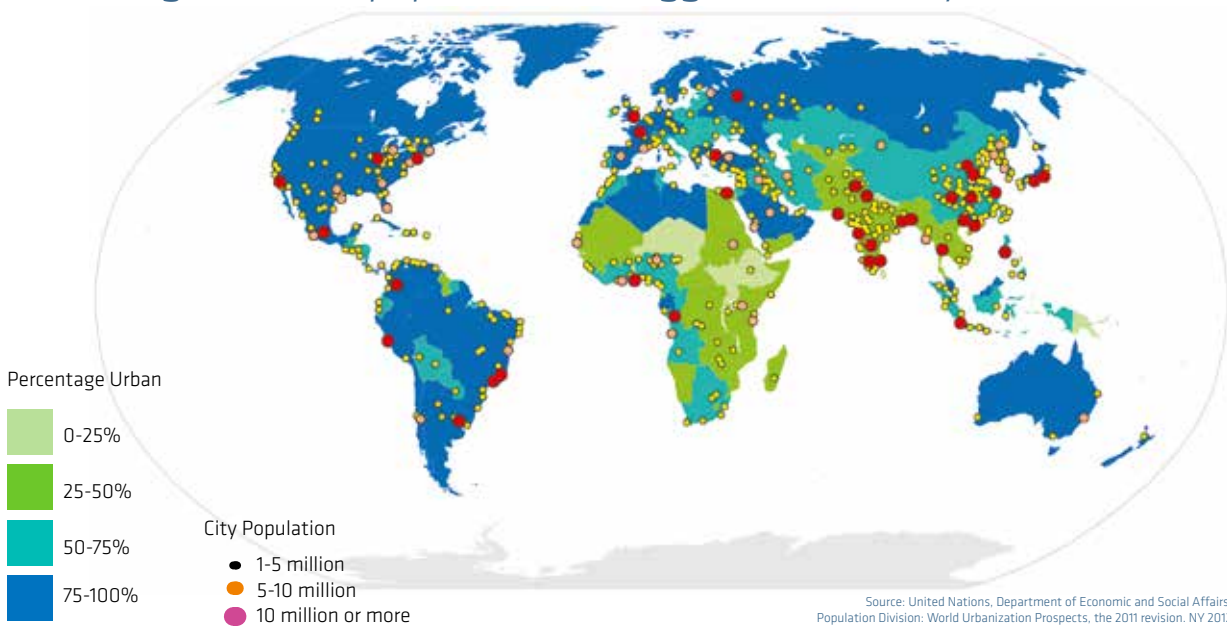

Source: United Nations, Department of Economic and Social Affairs, Population Division: World Urbanization Prospects, the 2011 revision. NY 2012

Railway Main Line Cables

Development of technology

The safety requirements for the railway technology are extraordinary and similar to that in aviation or aerospace. With increasing traffic volume in both directions on single track lines, continuous monitoring which provides permanent communication between the train conductor's cab and the railway control center is essential for the railway line safety. The rail vehicles cannot leave their track in case of imminent collision by opposing traffic on the same track.

In Europe, there has been a number of train control technologies that worked well within the country borders, but, led to considerable additional costs in the cross-border traffic. Currently, locomotives have more than one train control system installed, which ensure safe participation in railway traffic in neighboring countries without the need to change the locomotive.

Research aimed at reducing the number of systems and develop a uniform operational management approach for railways across Europe already started in the 80's on behalf of the International Union of Railways (UIC) and the European Rail Research Institute (ERRI). In April 2000, the guidelines for adopting specifications were presented under the name ERTMS - European Rail Traffic Management System.

The ERTMS system mainly consists of the following components:

- ETCS (European Train Control System) is a train control system, which is intended to prevent a train entering an occupied sector, or running at too high speed, using interlocking electronic control systems, with integrated train and trackside elements.

- GSM-R (Global System for Mobile Communications - Railway) is a mobile communications system for railway data and voice communications between moving trains and fixed locations, designed to satisfy the highest safety standards.

ERTMS was initially developed for intercity trains on routes of Trans-European Networks (TEN), but is gaining worldwide attention and it is being implemented outside Europe as well.

Another well recognized railway technology is CBTC - Communication Based Train Control system. CBTC systems are commonly used for urban rail traffic such as underground railways, light rail vehicles and trams, in urban areas with short transportation systems.

Both ETCS and CBTC systems are based on the same principles, namely high safety level in highly dense traffic. However, CBTC goes one step further and offers fully automated train operation. The train starts and stops automatically without a driver.

Even though CBTC complies with international standards the systems of each individual developer are not freely replaceable. The implementation of CBTC is highly complex and significantly more expensive than ERTMS on comparable routes. However, CBTC is unbeatable when it comes to achieving the shortest possible intervals between trains, down to 60-90 seconds. During the peak morning and evening periods, thousands of commuters can be comfortably transported and hence the streets can be relieved of congestion.



Prysmian Group has accompanied this development from the outset and today is able to offer a full range of cables for all applications in the railway sector.

Prysmian Group has the experience and the know-how to assist you and your projects worldwide.

Railway projects are unique!

Railway Main Line Cables



DSB

Index

Cables for any application	page 10
Explanation of symbols	page 13
Railway cable data sheets	page 17
Cables with reduction factor	page 64
Requirements for fire characteristics of cable installations in tunnels or stations	page 66
Fire testing	page 67
Construction Product Regulation	page 70
Transport and storage of cable drums	page 72
Important physical characteristics	page 73
Certifications and compliance	page 74
Our responsibilities	page 75
References	page 76

Railway Main Line Cables

Cables for any application

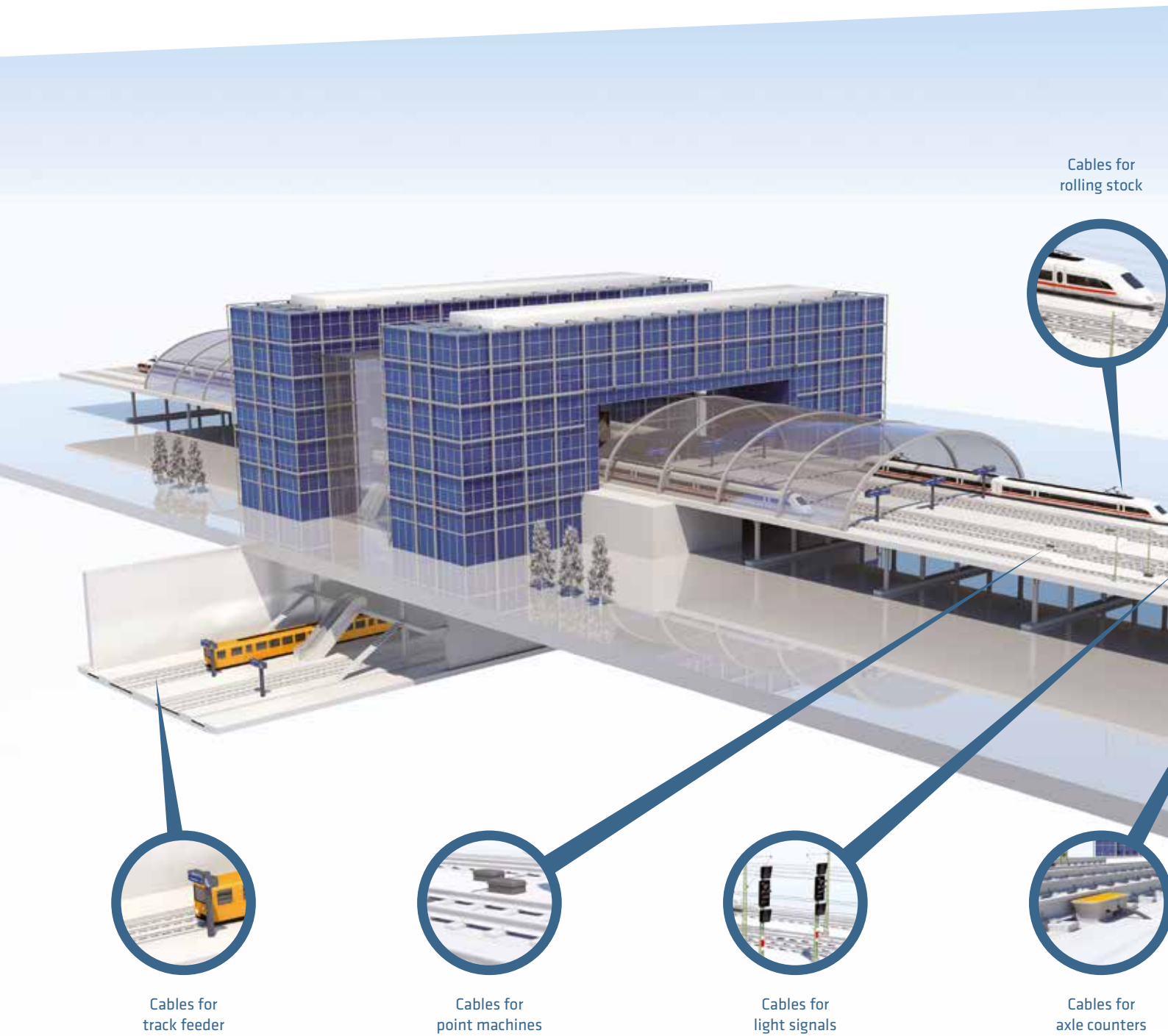

As the leading worldwide supplier, Prysmian Group offers an extensive range of cabling solutions for different railway network applications.

Typical cable applications for main railway lines include:

Substations and Transformers

- HV cables to substations for traction power
- MV cables to transformers for power distribution networks

Traction Power Networks

- MV cables for AC systems
- MV and LV cables for DC systems

Railway Network Systems

- MV and LV cables to distribute current to supervision and telecommunication systems, lighting, heating and real estate along the railway.

Grounding of Electrical Systems

- Bare conductors or insulated cables to guarantee the integrity of electrical systems.

Overhead Catenary Lines

- Cables to supply electric power to railway trains and to make them move.

Control and Signalling Systems

- Cables to cover a wide range of control and signalling applications to direct trains and keep trains clear of each other.

Mobile Communication Systems (GSM-R)

- Data and fiber optic cables for railway data and voice communication between moving trains and fixed locations.

Cables for catenary



Cables for balises

Railway Main Line Cables



Explanation of symbols



Conductor temperature

Max. conductor temperature °C in continuous operation.



Flexible installation

Due to IEC 60228 class 5 multi-standed conductor.



Smoke density

Smoke propagation acc. to EN/IEC 61034.



Halogen free

Halogen free acc. to EN/IEC 60754-1 and EN/IEC 50267-1.



Acidity

Corrosivity acc. to EN/IEC 60754-2.



Fire retardant

Flame propagation acc. to EN/IEC 60332-1.
Bundled and vertical acc. to EN/IEC 60332-3.



Screened or armoured

With either copper, aluminum or steel wire, foil and tape.



Fire resistant

Fire resistant acc. to EN/IEC 60331-1 & 2.



UV resistant

Filling and or outer sheath suitable for outdoor application.



EMC resistant

Fulfills EMC-directive with 100% dense screen with low coupling impedance.



Impact resistant

Against shocks.



Pull resistant

High tensile stress required to create cable failure.



Weather proof



Watertight or proof

Axial and radial water blocking via water swellable tape or yarn.

Railway Main Line Cables

Index of data sheets

1. Electrification of Main Lines

1.1 Transformer station

Cables to feed substations and transformers	Al, watertight	PEX-AL-LRT 170 kV	17
---	----------------	-------------------	----

1.2 Traction power network

Cables to feed traction power networks	Al, watertight	PEX-AL-LT 52 kV	18
	CU, watertight	PEX-CU-LT 17.5 kV	19

1.3 Railway network system

Current distribution from transformer to different railway network systems	Al, class 1	HIK-AL-M 0.6/1 kV	20
	Al, class 2	HIK-AL-S 0.6/1 kV	21
	CU, flexible	Afumex Easy RZ1-K 0.6/1 kV	22
	CU, armoured	HIKA 300/500 V	24
	CU, grounding	HIKAJ 300/500 V	25

1.4 Grounding and Inter-connection

Grounding of metal part of electrical systems and connection cables	CU conductor	HK	26
	Al wire, insulated	HIL-AL-R 0.6/1 kV	27
	Al cable	HIK-AL-R 0.6/1 kV	28
	CU cable, flexible	H07Z-K 450/750 V	29

1.5 Accessory

For LV and MV systems	Multi-connector	FORMFIT 12-36 kV	30
	Connector, tee	ELASCON 12-36 kV	31
	Joint, straight	ELASPEED 12-36 kV	32
	Joint, straight	ECOSPEED 24-36 kV	33
	Joint, EPR	SIXTY-SPEED 72.5 kV	34
	Termination, silicone	COLDFIT 72.5 kV	35

Many more cable types and tailor-made cables are available for your individual application.

(C) Prysmain Group Denmark 20.12.2017

Popular railway cable data sheets

2. Overhead Catenary Line

2.1	Catenary contact wire	Pure copper	TRL	37
		Copper-silver alloyed	TRL CuAg	38
2.2	Catenary wire	Bronze alloyed	KK Bz-II 50mm ²	39
2.3	Dropper	Bronze alloyed	KK Bz-II 10mm ²	39
		CU, multi-stranded	KKM Bz-II 10mm ²	40
2.4	Return wire	Al/steel conductor	ACSR 328-AL1/46-ST1A DOVE	41
		Al/steel insulated	ACSR 328-AL1/46-ST1A DOVE PEX	42

3 Signalling and Control

3.1	Signalling	Watertight & armoured	A-2Y0F(L)2YB2Y	44
		Watertight & HF	AJ-2Y0F(L)2YDB2Y	46
		Armoured	A-2Y2YB2Y	48
		Signal & axle counter	AJ-2Y(L)2YDB2Y	50
3.2	Control	HFFR	MCCCMK-HF EMC 0.6/1 kV	52
		FR	MCCMO-HF C-Pro 450/750 V	54
		Armoured	HKA 300/500 V	55

4. Communication

4.1	Along the track	Duct, blowing	A-DQ2Y	57
4.2	Connectivity	Joint	Compact Multi-function Joint (CMJ)	58
		Shelf 1U	SRS3000 Splice & Patch Shelf	60



SUBSTATION

PEX-AL-LRT 170 kV

SCREENED

Application

Underground high voltage transmission cable from substation to traction power feeding. Manufactured using triple extrusion process with completely dry curing and cooling by nitrogen gas.

Technical data

Rated voltage:

- > 87/150 (170) kV

Bending radius:

- > During pulling: 15 x D
- > Fixed: 13 x D

Pulling force:

- > 30 kN/mm²

Sideway pressure (T/R):

- > 10 kN/m

Standard

- > IEC 60840
- > IEC 60228

Construction

Conductor:

- > Round
- > Compacted aluminium wires
- > Stranded acc. to IEC 60228 class 2.
- > Longitudinal waterwight

Conductor screen:

- > Semi-conductive polymer compound

Insulation:

- > XLPE

Insulation screen:

- > Semi-conductive polymer compound

Wrapping:

- > Semi-conductive water blocking tape

Screen:

- > Copper wires and copper contact tape

Seperation layer:

- > Waterblocking / binder tape

Radial water barrier:

- > Aluminium foil laminated

Outer sheath:

- > HDPE
- > Extruded semi-conducting layer
- > Black



Content is subject to changes acc. to current product development and or any changes to standards.

Conductor cross-section mm ²	Outer diameter nom. mm	Weight kg/km	Screen cross-section mm ²	Standard length m
1 x 630/215	81	7.6	215	

Conductor cross-section mm ²	Screen DC resistance at 20°C Max. Ω/km	Capacitance in operation nom. µF/km	Short circuit current phase conductor max. kA/1 sec.	Short circuit current CU wire screen kA/1 sec.
1 x 630/215	0.0469	0.20	50	40

1. Electrification of main lines

TRACTION POWER NETWORK

PEX-AL-LT 52 kV

SCREENED & WATERTIGHT



Application

Halogen free single-core power supply cable. Longitudinal watertight with copper screen and water swelling tape. Suitable for installation directly in the ground or in ducts.

Technical data

Rated voltage:

- > 26/45 (52) kV AC

Test voltage:

- > 65 kV AC

Bending radius:

- > During installation: 15 x D
- > Single bend: 13 x D

Temperature range

- > Max. conductor temperature: +90°C
- > Short circuit temperature: +250°C
- > Lowest temp. at installation: -15°C
- > Below 0°C exercise caution

Standard

- > IEC 60840
- > IEC 60228

Construction

Conductor:

- > Round
- > Aluminium wire
- > Stranded acc. to IEC 60228 class 2.
- > Longitudinal watertight

Conductor screen:

- > Extruded semi-conductive PE

Insulation:

- > XLPE

Insulation screen:

- > Extruded semi-conductive PE

Tape:

- > Semi-conductive and water swellable

Screen:

- > Concentric screen of copper wires
- > Helix of copper tape

Outer sheath:

- > Halogen free PE compound
- > Black

Material property

- > Halogen free: IEC 60754-1
- > Acidity: IEC 60754-2

Content is subject to changes acc. to current product development and or any changes to standards.

Conductor cross-section mm ²	Outer diameter mm	Weight kg/km	Tensile strength kN	Bending radius at installation mm	Standard length m
1 x 240+75	49.1	2,580	8.5	780	1000-K26
1 x 400+75	55.2	3,240	12.1	870	1000-K26
1 x 500+75	58.3	3,640	15.0	915	1000-K28

Conductor cross-section mm ²	Outer diameter mm	Insulation thickness nom. mm	Diameter over insulation mm	Screen cross-section mm ²	Outer sheath thickness mm
1 x 240+75	18.1	9.0	37.3	75	2.4
1 x 400+75	23.7	9.0	42.9	75	2.6
1 x 500+75	26.6	9.0	45.8	75	2.7

TRACTION POWER NETWORK

PEX-CU-LT 17.5 kV

SCREENED, WATERTIGHT & UV RESISTANT

Application

Halogen free, flame retardant and longitudinal watertight single-core utility cable with copper screen and UV resistant sheath. Suitable for installation in pipes or directly in the ground. Can as well be ploughed down.

Technical data

Rated voltage:

- > 8.7/15 (17.5) kV AC

Bending radius:

- > Bending radius: 10 x D

Temperature range

- > Max. conductor temperature: +90°C
- > Short circuit temperature: +250°C
- > Lowest temp. at installation: -15°C
- > Below 0°C exercise caution

Standard

- > IEC 60502

Construction

Conductor:

- > Round
- > Copper wire
- > Stranded acc. to IEC 60228 class 2.
- > Longitudinal watertight

Conductor screen:

- > Extruded semi-conductive polymer

Insulation:

- > XLPE, halogen free
- > Nom thickness 4.5 mm

Insulation screen:

- > Extruded semi-conductive polymer

Screen:

- > Concentric screen of copper wires
- > Helix of copper tape

Outer sheath:

- > Halogen free polymer
- > UV stabilised
- > Red

Material property

- > Halogen free: IEC 60754-1
- > Acidity: IEC 60754-2
- > Flame retardant: IEC 60332-1



Content is subject to changes acc. to current product development and or any changes to standards.

Conductor cross-section mm ²	Outer diameter mm	Weight kg/km	Standard length m	Bending radius at installation mm	Tensile strength kN
1 x 150+25	33	2,200	500 - K14	495	7.5
1 x 240+35	37	3,250	500 - K16	55	12.0

Conductor cross-section mm ²	DC resistance at 20°C Ω/km	Capacitance per phase μF/km	Reactance Triangle Ω/km	Short circuit current for conductor kA/1 sec.	Short circuit current for screen kA/1 sec.
1 x 150+25	0.124	0.30	0.11	21.4	5.0
1 x 240+35	0.0754	0.36	0.11	34.3	7.0

1. Electrification of main lines

RAILWAY NETWORK SYSTEM

HIK AL-M 0.6/1 kV

HALOGEN FREE & SOLID CONDUCTOR

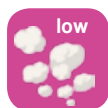
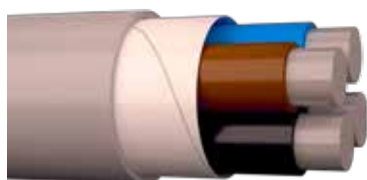

Application

Halogen free and flame retardant cable with low smoke and corrosive gas emission during fire. Suitable for application indoors and outdoors in pipes, trays or for direct burial. Can be ploughed down with caution.

Technical data

- > Rated voltage: 0.6/1 kV
- > Test voltage: 4,000 V
- > Bending radius: 15 x D

Temperature range

- > Max. conductor temperature: +90°C
- > Short circuit temperature: +250°C
- > Lowest temp. at installation: -20°C
- > Below 0°C exercise caution

Standard & Directive & Approval

Standard:

- > Cenelec HD 604-5D, IEC 60502-1
- > Cenelec N1ZC7Z1-U (R-S), N1ZA5Z1-U

Directive:

- > Fulfills LVD, RoHS & REACH

Approval:

- > CPR class: Eca
- > DoP no.: 1002845 ($\leq 25 \text{ mm}^2$)
- > DoP no.: 1004273 ($\geq 50 \text{ mm}^2$)

Construction

Conductor:

- > Round aluminium wire
- > Annealed and solid
- > Acc. to IEC 60228 class 1.
- > From 16-25mm² : round
- > From 150-240mm² : sector shaped

Insulation:

- > XLPE

Core colouring:

- > 4-core: brown, black, grey, blue
- > 5-core: brown, black, grey, blue, yellow/green

Separator:

- > Plastic tape

Outer sheath:

- > Halogen free compound
- > UV resistant
- > Grey

Material property

- > Flame retardant: IEC 60332-1
- > Halogen free: IEC 60754-1
- > Acidity: IEC 60754-2
- > Smoke density: IEC 61034
- > Current load: Acc. to SB 2001:6

Content is subject to changes acc. to current product development and or any changes to standards.

Conductor cross section mm ²	Outer diameter mm	Weight kg/km	Max. current load A	Standard length m	Prysmian EAN no.
4 x 16	20.0	506	77	1000	4741532901002
5 G 16	21.3	582	77	1000	4741532901026
4 x 25	24.0	740	97	1000	4741532901019
5 G 25	25.6	856	97	1000	4741532901033
4 x 50	25.4	775	146	1000	5701498014849
4 x 95	33.2	1,393	227	1000	5701498014887
4 x 150	40.1	2,104	304	1000	5701498014931
4 x 240	49.7	3,485	409	1000	5701498014986

RAILWAY NETWORK SYSTEM

HIK AL-S 0,6/1 kV

HALOGEN FREE & STRANDED CONDUCTOR

Application

Halogen free and flame retardant cable with low smoke and corrosive gas emission during fire. Suitable for application indoors and outdoors in pipes, trays or directly in the ground. Can be ploughed down with caution.

Technical data

- > Rated voltage: 0,6/1 kV
- > Test voltage: 4,000 V
- > Bending radius: 15 x D

Temperature range

- > Max. conductor temperature: +90°C
- > Short circuit temperature: +250°C
- > Lowest temp. at installation: -20°C
- > Below 0°C exercise caution

Standard & Directive & Approval

Standard:

- > Cenelec HD 604-5D, IEC 60502-1

Directive:

- > Fulfills LVD, RoHS & REACH

Approval:

- > CPR class: Eca
- > DoP no. 1002844

Construction

Conductor:

- > Round aluminium wire
- > Annealed and stranded
- > Acc. to IEC 60228 class 2.
- > Sector shaped

Insulation:

- > XLPE

Core colouring:

- > 4-core: brown, black, grey, blue

Seperator:

- > Plastic tape

Outer sheath:

- > Halogen free compound
- > UV resistant
- > Grey

Material property

- > Flame retardant: IEC 60332-1
- > Halogen free: IEC 60754-1
- > Acidity: IEC 60754-2
- > Smoke density: IEC 61034
- > Current load: Acc. to SB 2001:6



Content is subject to changes acc. to current product development and or any changes to standards.

Conductor cross section mm ²	Outer diameter mm	Weight kg/km	Max. current load A	Standard length m	Prysmian EAN no.
4 x 50	27.7	900	146	1000	5701498014719
4 x 70	31.0	1,180	187	1000	4741532901040
4 x 95	35.1	1,450	227	1000	5701498014726
4 x 120	42.0	1,945	263	1000	4741532901057
4 x 150	43.6	2,210	304	1000	5701498014733
4 x 185	48.0	2,925	347	1000	4741532901064
4 x 240	53.7	3,485	409	500	5701498014740
4 x 300	59.0	4,575	471	500	4741532900043

1. Electrification of main lines

RAILWAY NETWORK SYSTEM

RZ1-K 0.6/1 kV

FLEXIBLE & UV RESISTANT

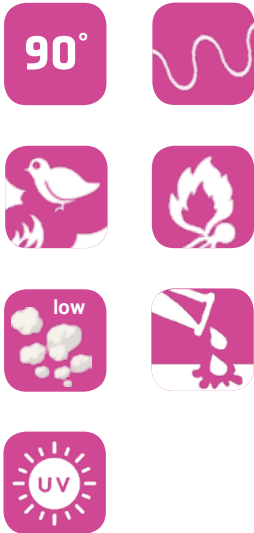
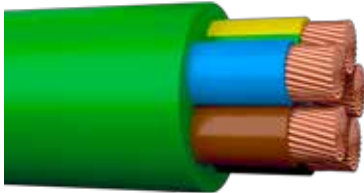

Application

Halogen free installation cable with high flexibility and low bending radius. Suitable for installation in machines and factories either in cable pipes, trays or cabinets. The cable is UV resistant and can be applied outdoors and indoors as well as directly in the ground.

Technical data

Rated voltage:

- > 0.6/1 kV

Test voltage:

- > 3,500 kV

Bending radius:

- > Fixed < 25 mm: 4 x D
- > During installation > 25 mm: 5 x D
- > Ploughed down > 50 mm: 6 x D

Temperature range

- > Max. conductor temperature: +90°C
- > Short circuit temperature: +250°C
- > Lowest temp. at installation: -40°C

Standard & Directive & Approval

Standard:

- > Cenelec UNE 21123-4
- > IEC 60502-1

Directive:

- > Fulfills LVD, RoHS & REACH

Approval:

- > CPR class: Cca- s1bd1a1
- > DoP no.: See table

Construction

Conductor:

- > Round copper wires
- > Annealed
- > Multi-stranded
- > Acc. to IEC 60228 class 5.

Insulation:

- > XLPE
- > UV resistant

Core colouring:

- > 1-core: Green/yellow
- > 3-core: Green/yellow, blue, brown
- > 4-core: Green/yellow, brown, black, grey
- > 4-core: Blue, brown, black, grey
- > 5-core: G/Y, blue, brown, black, grey

Outer sheath:

- > Halogen free compound
- > Green

Material property

- > Flame retardant: IEC 60332-3-24 cat. 3
- > Halogen free: IEC 60754-1
- > Acidity: IEC 60754-2
- > Smoke density: IEC 61034
- > Current load: Acc. to SB 2001:6

Conductor cross-section mm ²	Outer diameter mm	Weight kg/km	Standard length m	Max. current load in freeair at 30°C A	DoP no.	Prysmian EAN no.
1 G 6	7.3	96	500	54	1000780	8430220087987
1 G 10	8.4	140	500	75	1000781	8430220087956
1 G 16	9.4	195	500	100	1000782	8430220087970
1 G 25	11.0	290	500	135	1000783	8430220087994
1 G 35	12.6	395	500	169	1000784	8430220087963
1 G 50	14.3	550	500	207	1000814	8430220088144
1 G 70	16.2	750	500	268	1000815	8430220088168
1 G 95	17.9	970	500	328	1000816	8430220088113
1 G 120	20.0	1,200	500	383	1000817	8430220088151
1 G 150	22.3	1,480	500	444	1000818	8430220088069
1 G 185	24.5	1,866	500	510	1000819	8430220088076
1 G 240	27.4	2,350	500	607	1000820	8430220088083
1 G 300	29.7	3,063	500	703	1000821	8430220088106
2 G 1.5	8.7	105	500	26	1000750	8430220087857
2 G 6	11.7	230	500	63	1000752	8430220087864
2 G 10	14.0	345	500	86	1000786	8430220087666
2 G 16	16.9	503	500	115	1000787	8430220087680
3 G 1.5	9.2	120	500	26	1000753	8430220087871
3 G 2.5	10.1	160	500	36	1000754	8430220087895
3 G 4	11.4	215	500	49	1000755	8430220087888
3 G 6	12.6	282	500	63	1000788	8430220087697
3 G 10	14.9	430	500	86	1000789	8430220087673
3 G 16	17.2	601	500	115	1000790	8430220087734
4 G 1.5	9.9	145	500	23	1000756	8430220087901
4 G 2.5	11.0	195	500	32	1000757	8430220087925
4 G 4	12.4	260	500	42	1000795	8430220087727
4 G 6	13.7	350	500	54	1000796	8430220087796
4 x 10	16.4	540	500	75	1000792	8430220087710
4 G 10	16.4	540	500	75	1000797	8430220087703
4 x 16	19.8	810	500	100	1000793	8430220087826
4 G 16	19.8	810	500	100	1000798	8430220087741
4 x 25	23.7	1,233	500	127	1000794	8430220087802
4 x 35	26.4	1,711	500	158	1000822	8430220088120
4 x 50	30.8	2,386	500	192	1000823	8430220088052
4 x 70	35.3	3,240	500	246	1000824	8430220088137
4 x 95	40.1	4,380	500	298	1000825	8430220088090
4 x 150	50.8	6,800	500	399	1000826	8430220088021
4 x 185	56.7	8,560	500	456	1000827	8430220088014
4 x 240	63.3	10,940	500	538	1000828	8430220088045
5 G 4	13.4	315	500	42	1000799	8430220087789
5 G 6	14.9	420	500	54	1000800	8430220087833
5 G 10	18.0	660	500	75	1000801	8430220087772
5 G 16	21.6	990	500	100	1000802	8430220087758
5 G 25	26.0	1,490	500	127	1000803	8430220087840
5 G 35	30.6	2,160	500	158	1000760	8430220088038
5 G 50	34.3	2,763	500	192	1000761	8430220088007

1. Electrification of main lines

RAILWAY NETWORK SYSTEM

HIKA 300/500 V

ARMOURED

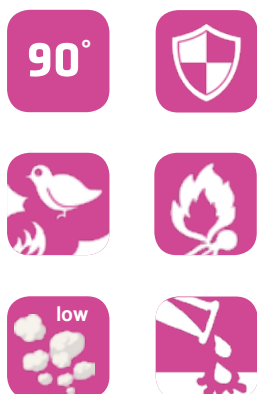
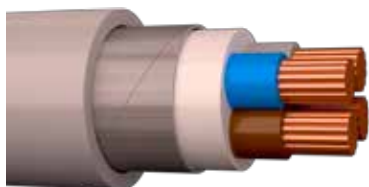

Application

Halogen free light installation cable applicable for areas that require extra mechanical protection. Fulfills requirements for rodent protection. Suitable for indoor and outdoor installation in pipes, trays, directly in the ground or in non-vibrated cement. Insulation must be protected from UV-light.

Technical data

Rated voltage:

- > 300/300 AC

Test voltage:

- > 2,000 V

Bending radius:

- > 10 x D

Temperature range

- > Max. conductor temperature: +70°C
- > Short circuit temperature: +250°C
- > Max. installation temperature: -20°C
- > Min. operating temperature: -40°C

Standard & Directive & Approval

Standard:

- > Partially adapted to DS 2393-3

Directive:

- > Fulfills LVD, RoHS & REACH

Approval:

- > CPR class: Eca
- > DoP no. - see table

Construction

Conductor:

- > Round copper wires
- > Solid or stranded
- > Acc. to IEC 60228 class 1 and 2.

Insulation:

- > XLPE

Core colouring:

- > 4-core: blue, brown, black, grey
- > 7-core: blue, brown, black, grey, white, red, black

Filling:

- > Halogen free compound

Armouring:

- > Galvanized steel band
- > Coverage 100%

Outer sheath:

- > Halogen free compound
- > Grey

Material property

- > Halogen free: IEC 60754-1
- > Acidity: IEC 60754-2
- > Flame retardant: IEC 60332-1
- > Smoke density: IEC 61034
- > Current load acc. to SB2006:6

Content is subject to changes acc. to current product development and or any changes to standards.

Conductor cross-section mm ²	Outer diameter mm	Weight kg/km	Standard length m	DoP no.	Prysmian EAN no.
4 x 4	12.8	307	500	1003090	8711401010025
4 x 10	18.2	700	500	1003932	8711401009890
4 x 16	21.0	1,000	500	1003089	8711401009968
7 x 1.5	11.8	236	500	1003095	8711401010629
7 x 2.5	13.0	312	500	1003096	8711401010643
7 x 2.5	13.0	312	2,000	1003096	8711401010728
7 x 4	14.9	435	500	1003097	8711401010933

RAILWAY NETWORK SYSTEM

HIKAJ 300/500 V

ARMoured WITH GROUNDING WIRE

Application

Halogen free light installation cable applicable for areas that require extra mechanical protection. Fulfills requirements for rodent protection. Suitable for indoor and outdoor installation in pipes, trays, directly in the ground or in non-vibrated cement. Insulation must be protected from UV-light.

Technical data

Rated voltage:

- > 300/300 AC

Test voltage:

- > 2,000 V

Bending radius:

- > 10 x D

Temperature range

- > Max. conductor temperature: +70°C
- > Short circuit temperature: +250°C
- > Max. installation temperature: -20°C
- > Min. operating temperature: -40°C

Standard & Directive & Approval

- > Standard: Partially adapted to DS 2393-3
- > Directive: Fulfills LVD, RoHS & REACH
- > Approval: CPR class: Eca
- > DoP no. - see table

Construction

Conductor:

- > Round copper wires
- > 1.5 - 6 mm²: Solid
- > > 10 mm²: Stranded

Insulation:

- > XLPE

Core coloring:

- > 3-core: green/yellow, blue, brown
- > 4-core: green/yellow, blue, brown, black
- > 5-core: g/y, blue, brown, black, grey
- > 7-core: green/yellow, blue, brown, black, grey, white, red

Filling:

- > Halogen free compound

Armouring:

- > Galvanized steel band
- > Coverage 100%

Outer sheath:

- > Halogen free compound, grey

Material property

- > Halogen free: IEC 60754-1
- > Acidity: IEC 60754-2
- > Flame retardant: IEC 60332-1
- > Smoke density: IEC 61034
- > Current load acc. to SB2006:6



Conductor cross-section mm ²	Conductor type	Outer diameter mm	Weight kg/km	Standard length m	DoP no.	Prysmian EAN no.
3 G 1.5	Class 1	9.6	143	100	1003081	8711401008947
3 G 1.5	Class 1	9.6	143	500	1003081	8711401009173
3 G 2.5	Class 1	10.4	179	500	1003085	8711401009425
4 G 1.5	Class 1	10.3	167	100	1003082	8711401009265
4 G 1.5	Class 1	10.3	167	500	1003082	8711401052208
5 G 1.5	Class 1	11.1	196	100	1003083	8711401008923
5 G 1.5	Class 1	11.1	196	500	1003083	8711401009296
5 G 2.5	Class 1	12.1	253	100	1003086	8711401009739
5 G 2.5	Class 1	12.1	253	500	1003086	8711401009777
5 G 6	Class 1	15.2	460	500	1003087	8711401009821
5 G 10	Class 2	20.0	842	500	1003088	8711401009852
5 G 16	Class 2	23.2	1,214	500	1003931	8711401009876
7 G 1.5	Class 1	11.8	236	100	1003084	8711401009371
7 G 1.5	Class 1	11.8	236	500	1003084	8711401052292

1. Electrification of main lines

GROUNDING

HK

STRANDED ANNEALED COPPER CONDUCTOR



Application

Annealed copper wire for grounding of metal parts from transformer station to different systems of railway networks.

Technical data

Bending radius:

- > During installation: 15 x D
- > Fixed: 10 x D

Pulling force:

- > Using eye or grip: max. 50 N/mm²

Standard & Directive

Standard:

- > IEC 60228

Directive:

- > Fultills RoHS

Construction

Conductor:

- > Round
- > Copper wires
- > Annealed
- > Stranded acc. to IEC 60228 class 2.

Content is subject to changes acc. to current product development and or any changes to standards.

Conductor cross-section mm ²	Outer diameter mm	Weight kg/km	Standard length m	Prysmian EAN no.
1 x 16	5.1	145	500 - K6	6410001053167
1 x 16	5.1	145	25	6410001052054
1 x 16	5.1	145	50	6410001052061
1 x 16	5.1	145	100	6410001052078
1 x 25	6.5	225	500 - K6	6410001053273
1 x 25	6.5	225	100	6410001053259
1 x 25	6.5	225	50	6410001053242
1 x 25	6.5	225	25	6410001053235
1 x 35	7.6	315	1000 - K7	6410001053358
1 x 50	9	430	1000 - K7	6410001053501
1 x 70	11	610	1000 - K9	6410001053709
1 x 95	13	850	1000 - K11	6410001053952
1 x 120	15	1,100	500 - K11	6410001053976
1 x 150	16	1,312	500 - K11	6410001050142

GROUNDING

HIL AL-R 0.6/1 kV

INSULATED ALUMINIUM WIRE

Application

Halogen free and flame retardant cable with low emission of smoke and corrosive gasses during fire. Suitable for installation in buildings or as grounding cable indoor and outdoors in cable trays or directly in the ground.

Technical data

Rated voltage:

- > 0.6/1 kV

Test voltage:

- > 4,000 V

Bending radius:

- > 15 x D

Tensile strength:

- > Max. 30N/mm²

Temperature range

- > Max. conductor temperature: +90°C
- > Short circuit temperature: +250°C
- > Lowest temp. at installation: -5°C

Standard & Directive & Approval

Standard:

- > Dimensioned acc. to EC 60502-1 and Bane Danmark's specifications.

Directive:

- > Fulfills LVD, RoHS and REACH

Approval:

- > CPR class: Eca
- > DoP no. : 1002847

Construction

Conductor:

- > Round aluminium wires
- > Stranded
- > Acc. to IEC 60228 class 2.

Conductor marking:

- > BaneDanmark

Insulation:

- > Thermoplastic compound
- > 1 layer

Core colouring:

- > 50-core: Green/yellow
- > 70-core: Black

Marking:

- > Prysmian HIL-AL-R 1 kV 1x50 mm²
- > BANEDANMARK PROPERTY, date

Material property

- > Flame retardant: IEC 60332-1
- > Halogen free: IEC 60754-1
- > Smoke density: IEC 61034
- > Acidity: IEC 60754-2

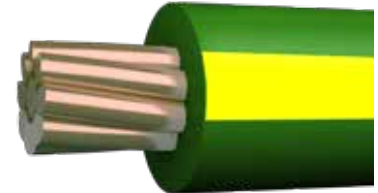

Content is subject to changes acc. to current product development and or any changes to standards.

Conductor cross-section mm ²	Number and diameter of wires	Sheath thickness mm	Outer diameter		Weight kg/km	Standard length m	BaneDanmark order no.
			Nom. mm	Max. mm			
1 G 50	19 x 1.78	1.4	11.8	12.8	137	500	183360050
1 G 70	19 x 2.14	1.4	13.5	14.5	231	500	183360070

1. Electrification of main lines

GROUNDING

HIK AL-R 0.6/1 kV

ALUMINIUM CABLE



Application

Halogen free and flame retardant cable with low emission of smoke and corrosive gasses during fire. Suitable for installation in buildings or as grounding cable indoor and outdoors in cable trays and ducts or directly in the ground.

Technical data

Rated voltage:

- > 0.6/1 kV

Test voltage:

- > 4,000 kV

Bending radius:

- > 15 x D

Tensile strength:

- > Max. 30 kN/mm²

Temperature range

- > Max. conductor temperature: +90°C
- > Short circuit temperature: +250°C
- > Lowest temp. at installation: -5°C

Standard & Directive & Approval

Standard:

- > Dimensioned acc. to DS 2393 and Bane Danmark's specifications.

Directive:

- > Fulfills LVD, RoHS & REACH

Approval:

- > CPR class: Eca
- > DoP no.: 1002843

Construction

Conductor:

- > Round aluminium wires
- > Stranded
- > Acc. to IEC 60228 class 2.

Conductor marking:

- > BaneDanmark

Insulation:

- > XLPE

Core colour:

- > 120-core: Green/yellow
- > 150-core: Black
- > 240-core: Black

Outer sheath:

- > Thermoplastic compound
- > 120-core: Green/yellow
- > 150-core: Black
- > 240-core: Black

Marking:

- > Prysmian HIK-AL-R 1 kV 1x50 mm²
- > BANEDANMARK PROPERTY

Material property

- > Flame retardant: IEC 60332-1
- > Halogen free: IEC 60754-1
- > Smoke density: IEC 61034
- > Acidity: IEC 60754-2

Content is subject to changes acc. to current product development and or any changes to standards.

Conductor cross-section mm ²	Number and diameter of wires	Outer cable diameter mm		Weight kg/km	Standard length m	BaneDanmark order no.
		Nom.mm	Max.mm			
1 G 120	19 x 2.90	18.5	20.0	605	500	183360120
1 G 150	37 x 2.34	20.5	22.1	711	500	183360150
1 G 240	37 x 3.01	25.6	27.5	912	500	183360240

GROUNDING

H07Z-K 450/750 kV

FLEXIBLE COPPER WIRE

Application

Halogen free, flame retardant and flexible panel wire, designed for the internal wiring of switchboards, distributor boards, machinery and lighting fixtures. Suitable for installation in ducts or pipes.

Technical data

- > Rated voltage: 450/750 V
- > Test voltage: 2,500 V
- > Bending radius: $\leq 8\text{mm}$: 4 x D,
- > $8 \leq 12\text{mm}$: 5 x D, $> 12 \leq 20\text{mm}$: 6 x D
- > $> 20\text{ mm}$: 6 x D

Temperature range

- > Max. conductor temperature: +90°C
- > Short circuit temperature: +250°C
- > Lowest temp. at installation: -40°C

Standard

- > UNE 21027-9, HD 22.9 S2 1
- > Bureau Veritas acc. to IEC 60092 Certificate no.: 11376/CO BV
- > $>50\text{ mm}^2$ not approved by Bureau Veritas

Construction

Conductor:

- > Round copper wires
- > Annealed
- > Multi-stranded
- > Acc. to IEC 60228 class 5.

Insulation:

- > Halogen free compound
- > Type IE5

Core colour:

- > Green/yellow

Material property

- > Flame retardant: IEC 60332-1 & 3
- > Halogen free: IEC 60754-1
- > Acidity: IEC 60754-2
- > Smoke density: IEC 61034-2
- > Current load: Acc. to SB 2001:6

Directives

- > Fulfills LVD, RoHS & REACH

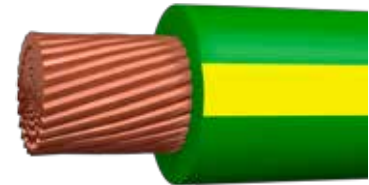

90°



Conductor cross-section mm ²	Outer diameter mm	Weight kg/km	Standard length m	Prysmian EAN no.
1 G 1.5	3.0	20	100	8430220452839
1 G 2.5	3.6	31	100	8430220452846
1 G 4	4.1	64	100	8430220452853
1 G 6	4.6	64	100	8430220452860
1 G 10	6.1	108	100	8430220452877
1 G 16	7.2	160	100	8430220452884
1 G 25	8.8	243	50	8430220452891
1 G 25	8.8	243	500	8430220452907
1 G 35	10.3	323	50	8430220452914
1 G 35	10.3	323	500	8430220452921
1 G 50	12.0	495	500	8430220452938
1 G 70	13.6	680	500	8430220452945
1 G 95	15.7	885	500	8430220452952
1 G 120	17.8	1,110	500	8430220452969
1 G 150	20.0	1,435	500	8430220452976
1 G 185	22.1	1,690	500	8430220452983
1 G 240	24.0	2,235	500	8430220452990

ACCESSORY

FORMFIT MULTI-CONNECTOR

12-36 kV SEPARABLE WITH TEST POINT



Application

Watertight separable connector suitable for connecting polymer up to 36 kV cables to transformers, switchgear units, motors etc. Available as a straight FMCS-400, elbow FMCE-400 or tee FMCT-400 connector. For indoor and outdoor application of:

- > Single core cables
- > PE, XLPE and ERP insulation
- > CU or AL conductor
- > Semi-conducting screen
- > Screen of metal, wire or tape
- > Insulation voltage up to 36 kV
- > From 25-240 (300) mm²
- > For continuous 400 A rms
- > Overload 600 A rms
- > Interface B

Installation features

- > No need for special tools
- > No need for heating, taping or filling
- > Vertical, angled or inverted position
- > No min. distance between phases
- > Immediate energizing possible
- > Individual clamping by steel brace

Construction

- > Contact pin assembly
- > Semi-conducting inner screen
- > Semi-conducting outer jacket
- > Insulating body of moulded EPDM
- > Test point electrically protected by cap
- > Adapter of EPDM moulding
- > Locking brace of stainless steel
- > Earthing cover of moulded EPDM
- > Earthing eye

Standard

- > VDE 0278-C 33-051, CC 33-001
- > HD 629-1 og IEC 60502-4
- > Cenelec EN 50180, EN 50181

Delivery

- > Supplied as a kit of 3 single connectors containing all components.

Content is subject to changes acc. to current product development and or any changes to standards.

Diameter over insulation		Kit reference no.	Conductor size in mm (for guidance only)			
Min.	Max.		12 kV	17 kV	24 kV	36 kV
18.5	20.5	FMCE-400-Z	70	50	35	
19.9	21.9	FMCE-400-A	95	70	50	
21.4	23.5	FMCE-400-B	120	95	70	25
22.9	25.1	FMCE-400-C	150	120	95	35
24.4	26.6	FMCE-400-D	185	150	120	50
26.0	28.3	FMCE-400-E	240	185	150	70
27.8	30.4	FMCE-400-F	300	240	185	95
29.8	32.7	FMCE-400-G		300	240	120/150
31.8	35.3	FMCE-400-H			300	185
34.1	38.3	FMCE-400-J				240

ACCESSORY

ELASCON TEE CONNECTOR

12-36 kV SEPARABLE WITH MECHANICAL CONTACT

Application

Watertight connector type MSCT/EC-630-C suitable for connecting polymer MV cables to transformers, switchgear units, motors etc. For indoor and outdoor application of:

- > Single core cables
- > PE, XLPE and ERP insulation
- > CU or AL conductor solid or stranded
- > Semi-conducting screen
- > Screen of metal, wire or tape
- > Insulation voltage up to 18/30 (36) kV
- > Conductor size: 25 - 300 mm²
- > For continuous 630 A rms
- > Overload 900 A rms

Installation features

- > No need for special tools
- > No need for heating, taping or filling
- > Vertical, angled or inverted position
- > No min. distance between phases
- > Immediate energizing possible

Standard

- > HD 629.1 S2
- > IEC 60502-4 NF C 33-051 - NF C 33-001
- > IEC 61238-1 class A - mechanical contact

Construction

- > Mechanical conductor contact
- > M16 clamping screw
- > Semi-conducting inner screen
- > Semi-conducting outer envelope
- > Insulating body mould EPDM
- > Test point electrically protected by cap
- > Insulating plug epoxy component
- > Cap of moulded semi-conducting EPDM
- > Earthing eye
- > Moulded high permittivity reducer

Standard

- > Cenelec HD 629.1 S2
- > IEC 60502-4 - NF C33-051 - NF C 33-001.
- > Cenelec EN 50180, EN 50181
- > IEC 61238-1 class A, HN 68-S-91

Versions available

- > Elascron is available in versoin for 250, 400 and 630 continuous A rms.

Delivery

- > Supplied as a kit of 3 single connectors containing all components.



Content is subject to changes acc. to current product development and or any changes to standards.

Voltage kV	Diameter over insulation		Conductor size in mm ² (for guidance only)		Kit reference no.
	Min.	Max.			
12	13.0	22.3	25	120	MSCEA/EC-630-C-12-rA-25/120
12	16.1	26.3	95	240	MSCEA/EC-630-C-12-rB-95/240
12	22.7	33.0	185	300	MSCEA/EC-630-C-12-rC-185/300
17	13.0	22.3	70	70	MSCEA/EC-630-C-17-rA-25/70
17	16.1	26.3	120	120	MSCEA/EC-630-C-17-rB-35/120
17	20.2	30.8	240	240	MSCEA/EC-630-C-17-rC-95/240
17	25.6	35.3	300	300	MSCEA/EC-630-C-17-rE-185/300
24	16.1	26.3	185	150	MSCEA/EC-630-C-24-rB-25/150
24	16.1	26.3	185	195	MSCEA/EC-630-C-24-rB-70/185
24	20.2	30.8	240	240	MSCEA/EC-630-C-24-rC-95/240
24	22.7	33.0	240	240	MSCEA/EC-630-C-24-rD-95/240
24	25.6	35.3	300	300	MSCEA/EC-630-C-24-rE-185/300
24	20.2	30.8	95	95	MSCEA/EC-630-C-36-rC-25/95
36	22.7	33.1	120	120	MSCEA/EC-630-C-36-rD-35/120
36	25.6	35.3	240	240	MSCEA/EC-630-C-36-rE-70/240

ACCESSORY

ELASPEED JOINT 12-36 kV

STRAIGHT THROUGH JOINT, ELASTIC



Application

For jointing of 1- or 3 core polymeric insulated cables of different specifications, conductor sizes, round or sector shaped. Joint has injected outer protection and integrated electrode. Suitable for jointing cables laid underground, in tunnels, on horizontal racks or aerial. Can be directly buried (after curing of resin). Supplied as a kit containing all the necessary components except the ferrules (supplied on request).

Elaspeed™ utilize cold shrink technology which doesn't require any special tools or torches for installation. The EPR rubber insulation is manufactured on a vertical extruder to ensure complete concentricity to the tightest tolerance possible.

Cable types

- > 1- or 3-core polymeric insulation
- > Copper or aluminium conductor
- > Metallic screen of tape or wire
- > Semi-conducting screen (extruded/taped)
- > Insulation voltage up to 36 kV (Um)
- > Conductor sizes from 25-500 mm²
- > Non-armoured or armoured.

Construction

- > Conductor ferrule, crimped
- > Joint body, extruded EPR
- > Removable carrier, pre-loaded
- > Core screen, copper
- > Outer protection, watertight

Installation features

- > No need for special tools or heating.
- > Injection of resin with disposable injection device can be supplied directly in the kit - in this case, letter "F" to be added at the end of kit reference.
- > Energizing of cable 30 minutes after injecting.
- > Polymerisation of synthetic resins at ambient temp. +5°C to +45°C

Standard

- > C 33 001 - DIN 57 278
- > IEEE 404 - IEC 60502-4
- > ENEL DJ 4853 - C 33 050-AI
- > CENELEC HD 629-1

Content is subject to changes acc. to current product development and or any changes to standards.

Rated voltage kV	1 core cable			3 core cable		
	Max. OD sheath mm	Max. conductor size mm ²	Kit reference name	Max. OD sheath mm	Max. conductor size mm ²	Kit reference name
12	38	95 - 150	EPJM - 1C-12 E	19.0	95 - 150	RTMJ - 3C-12 E
12	49	195 - 300	EPJM - 1C-12 F	23.1	185 - 300	RTMJ - 3C-12 F
12	50	240 - 400	EPJM - 1C-12 H	24.4	240 - 400	RTMJ - 3C-12 H
12	57	300 - 500	EPJM - 1C-12 IP	27.8	300 - 500	RTMJ - 3C-12 IP
17.5	34	70 - 120	EPJM - 1C-17 E	19.0	70 - 120	RTMJ - 3C-17 E
17.5	44	150 - 240	EPJM - 1C-17 F	23.1	150 - 240	RTMJ - 3C-17 F
17.5	46	195 - 300	EPJM - 1C-17 H	24.4	185 - 300	RTMJ - 3C-17 H
17.5	52	240 - 500	EPJM - 1C-17 IP	27.8	240 - 500	RTMJ - 3C-17 IP
24	39	50 - 95	EPJM - 1C-24 E	19.0	50 - 95	RTMJ - 3C-24 E
24	48	95 - 240	EPJM - 1C-24 F	23.1	95 - 240	RTMJ - 3C-24 F
24	50	120 - 300	EPJM - 1C-24 H	24.4	120 - 300	RTMJ - 3C-24 H
24	57	195 - 400	EPJM - 1C-24 IP	27.8	185 - 400	RTMJ - 3C-24 IP
36	50	50 - 150	EPJM - 1C-36 H	24.4	50 - 150	RTMJ - 3C-36 H
36	57	95 - 300	EPJM - 1C-36 IP	27.8	95 - 300	RTMJ - 3C-36 IP
36	67	195 - 630	EPJM - 1C-36 I			

ACCESSORY

ECOSPEED JOINT 24-36 kV

STRAIGHT THROUGH JOINT, COLD SHRINK

Application

Suitable for jointing of polymeric insulated cables of different specifications, for example as transition joint between extruded and paper insulated cables. Joint can be laid underground in tunnels, on horizontal racks or directly buried.

Cable types

- > Single core polymeric insulation
- > Insulation voltage up to 36 kV (Um)
- > Copper or aluminium conductor
- > Conductor sizes 50 to 630 mm²
- > Tape, wire or polylam metallic screen
- > Non-armoured
- > Semi-conducting screen

Selection guide

Select in the table below, the kit model corresponding to the insulation voltage Um (up to 24 kV or 36 kV), the diameter over insulation and over outer sheath.

Specify insulation voltage Um for 24 or 36 kV.

Select the screen continuity device according to the type of metallic screen of cable. T1 for polylam screen, T2 for tape screen and T3 for wire screen.

Construction

- > Three layers sleeve
- > Two layers sheath
- > Copper mesh
- > High permittivity tape
- > PVC tape
- > Sealing mastic tape
- > Embossed copper tape
- > PVC strip
- > Identification label

Standard

- > Fulfills IEC 60502-4
- > Fulfills CENELEC HD 629-1-2

Installation characteristics

- > All-in-one compact design
- > Factory expanded onto a support
- > No special skills or experience required
- > Easy assembling
- > No special tools or heating needed
- > Wide cables size range
- > Immediate energizing after jointing
- > Great flexibility
- > Suitable for compact insulated cables



Content is subject to changes acc. to current product development and or any changes to standards.

Rated voltage kV	Model type	Min. outer insulation diameter mm	Max. outer sheath diameter incl. screen mm	Conductor size range (for guidance only)
24 kV	Ecospeed 151556	19	40	50 - 240
24 kV	Ecospeed 162662	24	44	95 - 240
36 kV	Ecospeed 151656-0	23	40	50 - 120
36 kV	Ecospeed 202070-1	28	55	95 - 240
36 kV	Ecospeed 202070-3	34	55	300 - 630
36 kV	Ecospeed 252580-4	36	62	500 - 630

ACCESSORY

SIXTY-SPEED JOINT 72.5 kV

ALL-IN-ONE, FACTORY TESTED, COLD SHRINK EPR



Description

- > Factory pre-assembled
- > Factory pre-tested
- > Cold-shrink EPR joint
- > All-in-one design
- > Integrated link-devices
- > Integrated elastic outer sheath
- > Sectionalized version
- > Non-sectionalized version
- > Self-ejecting technology
- > Shear bolts mechanical connector
- > Tool free solution
- > LEAN product - few components

Application

- > Joint for single-core extruded cables (XLPE or EPR)
- > Copper or aluminium conductor
- > Copper wire screen or aluminium laminated sheath
- > Cable sizes from 120 mm² (240 kcmil) up to 1000 mm² (2000 kcmil)
- > Voltage: 36/69 (72.5 kV) (IEC)
- > Voltage: 39.8/69 kV (BIL 350 kV crest) (IEEE)
- > Suitable for buried installations also in presence of water table (1 m water-proof)

Installation features

- > Easy to install: No special tools are required (tool-free solution).
- > Quick assembling: Designed for reducing installation time. Main components are already expanded and placed in the correct position. Joint sealing simply done by removing supports from the outer sheath.
- > Self-ejecting supports: No special skill required for the installation.
- > 100% factory tested: Submitted to electrical test and partial discharges measurements before shipping.
- > 2 years shelf-life.

Additional options

- > Metallic casing as additional mechanical protection.
- > Coffin-box filled with resin as additional water protection suitable for concentric cross-bonding cable.
- > Heat-shrinkable outer protection instead of the integrated elastic outer sheath.

Qualification

- > Qualified in accordance to IEC 60840 and IEEE-404.
- > Short circuit tested (up to 40 kA/0.5 sec.)

Content is subject to changes acc. to current product development and or any changes to standards.

Product references	Rated voltage max. kV	Model type	Cross-section range mm ²	Cable insulation range mm	Max. outer diameter mm
CSJ(-X) 1072	72.5 kV	1	120-240	39.0-53.0	77.0
CSJ(-X) 1072	72.5 kV	2	300-1,000	52.0-71.0	89.0

ACCESSORY

COLDFIT TERMINATION 72.5 kV

FACTORY EXPANDED WITH MODULAR DESIGN

Application

Factory-expanded cold shrink silicone termination designed with factory-assembled moisture sealing components. Modular design allows for different creepage distances. Suitable for outdoor installation subject to severe climatic conditions. Installation without use of special tools.

- > Single core extruded cables (XLPE or EPR)
- > With CU or AL conductor
- > With wire screen or aminated sheath
- > Conductor size from 150-1,200 mm²

Technical data

- > Rated voltage: 36/69 (72.5) kV
- > Terminal body creepage: 2,100 mm
- > Modular creepage: 600 mm
- > Total creepage distance: 2,700 mm
- > Acc. to IEC 60815

Installation features

- > Easy to install - not tools needed
- > Quick assemble - LEAN few items
- > Extractable support - on plastic carrier
- > Vertical or angled position
- > Shear bolts mechanical connector
- > Excellent anti-tracking and hydrophobic
- > 100% factory tested
- > 2 year shelf-life

Construction

Insulation body:

- > Cold shrink element
- > Silicone rubber
- > Expanded into a spiral support

Stress cone:

- > Designed to ensure voltage control
- > Suitable for all cables
- > Semi-conducting silicone rubber

Sealing tube:

- > Upper and lower (conductor/earth)
- > Cold shrink silicone rubber
- > Expanded into a spiral support

Tape:

- > High permittivity tape
- > Sealing mastic and silicone tape
- > Ensures watertightness

Conductor lug:

- > Suitable for copper or aluminium

Standard

- > IEC 60840 / IEEE 404



Content is subject to changes acc. to current product development and or any changes to standards.

Rated voltage max. kV	Model type	Cross-section mm ²	Insulation thickness mm	Outer diamter max. mm	A mm	B mm	C mm	D mm	F creepage m
72.5 kV	1	150 - 500	33.5 - 48.8	57.0	750	146	186	1,000	> 2.25
72.5 kV	2	500 - 1,200	42.8 - 66.0	74.0	750	156	196	1,000	> 2.25

5 210-2



CATENARY CONTACT WIRE

TRL

PURE COPPER CONDUCTOR

Application

Copper wire for power transmission to electric railway lines. Suitable as catenary wire for AC and DC systems.

Standard

- > EN 50149 type A

Construction

Conductor:

- > Single strand
- > Pure copper - ETP
- > Hard drawn
- > Grooved
- > Identification marks acc. to EN 50149

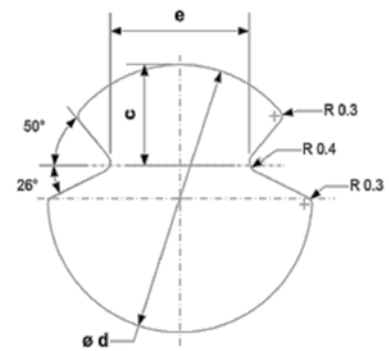
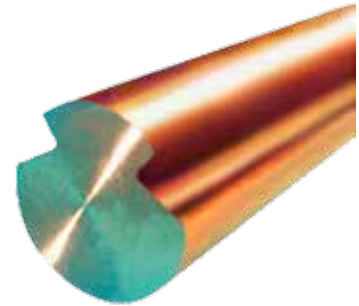

Content is subject to changes acc. to current product development and or any changes to standards.

Conductor cross-section mm ²	Conductor diameter mm	Weight kg/km	Standard length m	Prysmian order no.
80	10.6	710		0104008
100	12.0	890		0104010
120	13.2	1,067		

Conductor cross-section mm ²	Rated tensile strength (RTS) kN	Coefficient of linear expansion /°C	Final modulus of elasticity GPa	Thermal oxide resistance kA
80	28.4	17 x 10 ⁻⁶	120	12
100	35.5	17 x 10 ⁻⁶	120	15
120	42.0	17 x 10 ⁻⁶	120	

2. Overhead catenary lines

CATENARY CONTACT WIRE

TRL CuAg

COPPER-SILVER ALLOYED CONDUCTOR

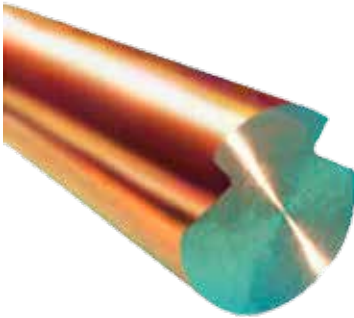

Application

Copper-silver alloyed wire for power transmission to electric railway lines. Suitable as catenary wire for AC and DC systems.

Standard

- > EN 50149

Construction

Conductor:

- > Copper-silver alloyed
- > Single strand
- > Hard drawn
- > Grooved
- > Identification marks acc. to EN 50149

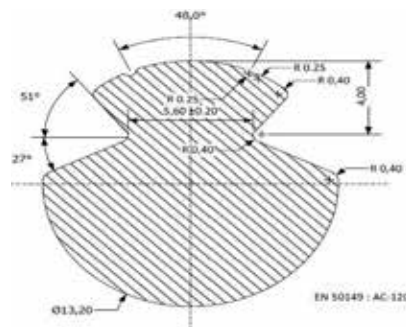
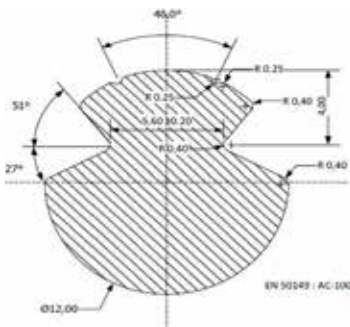

Content is subject to changes acc. to current product development and or any changes to standards.

Conductor cross-section mm ²	Outer diameter mm	Weight kg/km	Standard length m	Prysmian EAN no.
80	10.6	711		
100	12.0	980		
120	13.2	1067		

Conductor cross-section mm ²	Rated tensile strength (RTS) kN	Coefficient of linear expansion /°C	Final modulus of elasticity GPa	DC resistance at 20°C Ω/km
80	29.2	17 x 10 ⁻⁶	120	0.229
100	36.0	17 x 10 ⁻⁶	120	0.183
120	42.0	17 x 10 ⁻⁶	120	0.153

CATENARY WIRE & DROPPER

KK Bz-II 10 mm² or 50 mm²

STRANDED BRONZE ALLOYED COPPER CONDUCTOR

Application

Stranded bronze alloyed 1.35 or 3.0 mm copper wire concentrically stranded acc. to DIN 48201 part 2.

KK Bz-II 10 mm² suitable as dropper wire and KK Bz-II 50 mm² suitable as catenary wire in railway applications.

Construction

Conductor:

- > Round copper wires
- > Bronze alloyed
- > Hard drawn
- > Diameter nom: 1.35 mm or 3.0 mm
- > Stranded
- > Outer layer "Z" stranded

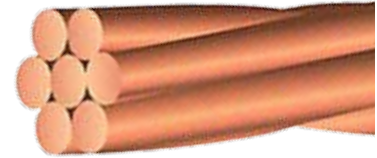

Technical data

Tensile strength:

- > Min. 618 N/mm²

Resistivity:

- > Max 27.78 nΩm

Standard

- > DIN 48201 part 2.
- > DIN 48200 part 2. for Bz-II

Content is subject to changes acc. to current product development and or any changes to standards.

Conductor cross-section mm ²	Outer diameter mm	Weight kg/km	Standard length m	Prysmian EAN no.
10 (7 x 1.35)	4.1	90		
50 (7 x 3.0)	9.0	446		

Conductor cross-section mm ²	Rated tensile strength (RTS) kN	Coefficient of linear expansion /°C	Final modulus of elasticity GPa	DC resistance at 20°C Ω/km
10 (7 x 1.35)	5.88	17 x 10 ⁻⁶	113	2.8
50 (7 x 3.0)	28.58	17 x 10 ⁻⁶	113	0.569

2. Overhead catenary lines

DROPPER

KKM Bz-II 10 mm²

MULTI-STRANDED COPPER ALLOYED CONDUCTOR

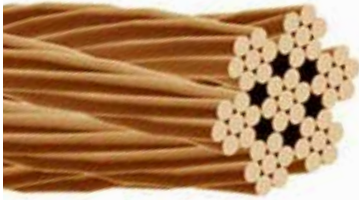

Application

Stranded bronze alloyed 0.5 mm copper wire concentrically bundled acc. to DIN 48201 part 2. Suitable as dropper wire in railway applications.

Technical data

Tensile strength:

- > Wires before stranding: Min. 618 N/mm²
- > Stranded conductor: Min. 589 N/mm²

Resistivity:

- > Wires before stranding: Max 27.78 nΩm

Construction

Conductor:

- > Round
- > Bronze alloyed copper wires
- > Hard drawn
- > Diameter nom: 0.5 mm ± 0.03
- > Bunched sub-conductor: 7 x 0.5 mm
- > Sub-conductor left handed "S" stranded
- > Outer layer right handed "Z" stranded

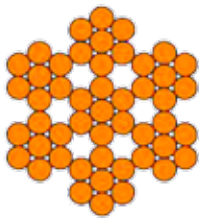

Standard

- > DIN 48200 part 2.
- > DIN 43138

Content is subject to changes acc. to current product development and or any changes to standards.

Conductor cross-section mm ²	Outer diameter mm	Sub-conductor diameter mm	Weight kg/km	Prysmian EAN no.
10 (7 x 7 x 0.5)	4.5	7 x 0.05	89	

Conductor cross-section mm ²	Rated tensile strength (RTS) kN	DC resistance at 20°C Ω/km	Direction of outer layer	Standard length m
10 (7 x 7 x 0.5)	589	2.98	Right handed	

RETURN WIRE

ACSR 328-AL1/46-ST1A DOVE

STEEL REINFORCED AL CONDUCTOR

Application

Cable for energy transmission designed with concentric layers, consisting on the outside of 26 aluminium wires and inside of 7 galvanized and fat enclosed steel wires. Suitable for fixed installation as return wire for outdoor railway applications.

Technical data

Short circuit current:

- > Max. 31.2 kA

Initial modulus of electricity of conductor:

- > 62 GPa/mm²

Standard

- > EN 50182:2001

Construction

Conductor:

- > Round
- > Outside 26 aluminium wires 3.72 mm
- > Inside 7 steel wires 2.89 mm
- > Steel core diameter 29.8 mm
- > Stranded
- > Outer layer right handed "Z" stranded

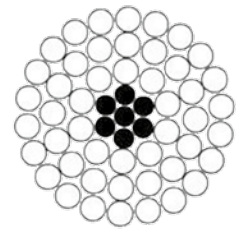

Content is subject to changes acc. to current product development and or any changes to standards.

Conductor cross-section mm ²	Outer diameter mm	Weight kg/km	Standard length m	Prysmian EAN no.
1 x 328 (33 wires)	23.6	1,139.6	2500 - K22	

Conductor cross-section mm ²	Rated tensile strength (RTS) kN	Coefficient of linear expansion /°C	Final modulus of elasticity GPa	DC resistance at 20°C Ω/km
1 x 328 (33 wires)	97.56	19.2 x 10 ⁻⁶	77	0.1022

2. Overhead catenary lines

RETURN WIRE

ACSR 328-AL1/46-ST1A DOVE

INSULATED STEEL REINFORCED AL CONDUCTOR



Application

PEX insulation cable for energy transmission. Designed with concentric layers consisting on the outside of 26 aluminium wires and inside of 7 galvanized and fat enclosed steel wires. Suitable for fixed installation as return wire for outdoor railway applications.

Technical data

Rated voltage:

- > 0.6/1 kV

Bending radius:

- > During installation 0.48 m

Standard

- > EN 50182:2001, IEC 60502-1

Temperature range

- > Max. operating temperature: +90°C
- > Short circuit temperature: +200°C
- > Min. temperature at installation: -15°C

Construction

Conductor:

- > Round
- > Stranded wires
- > Outer layers 26 aluminium wires 3.72 mm
- > Core 7 steel wires 2.89 mm
- > Steel core diameter 29.8 mm
- > Outer layer right handed "Z" stranded

Insulation:

- > PEX compound
- > Black

Sheath:

- > Halogen free compound
- > Black
- > UV resistant

Material property

- > Halogen free: IEC 60754-1
- > Acidity: IEC 60754-2

Content is subject to changes acc. to current product development and or any changes to standards.

Conductor cross-section mm ²	Outer diameter mm	Weight kg/km	Standard length m	Prysmian EAN no.
1 x 328 (33 wires)	23.0	1,595	1000 - K20	

Conductor cross-section mm ²	Rated tensile strength (RTS) kN	Coefficient of linear expansion /°C	Final modulus of elasticity GPa	DC resistance at 20°C Ω/km
1 x 328 (33 wires)	97.56	19.2 x 10 ⁻⁶	77	0.1022



SIGNALLING

A-2YOF(L)2YB2Y

HALOGEN FREE, WATERTIGHT & ARMoured

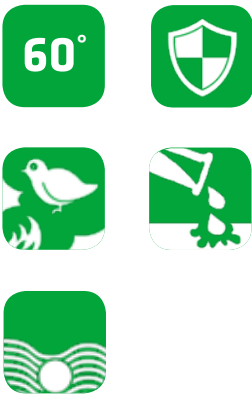
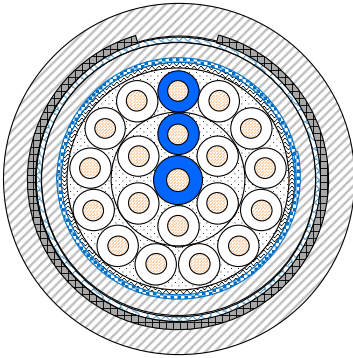

Application

For railway signalling applications, such as wiring of light signals, point machines, balises, axle counters and similar wayside equipment, up to 420 V AC or 600 V DC. The cable is longitudinally watertight with stranded copper conductor and steel tape armouring.

Technical data

Design:

- > n x 1 x diameter mm

Bending radius:

- > Flexible: $\geq 20 \times D$
- > Fixed: $\geq 15 \times D$

Temperature range

- > During installation: - 10°C to + 60°C
- > In operations: - 40°C to + 60°C

Standard

- > PH 416.0113 V2.1

Material property

- > Halogen free: IEC 60754-1 & 2

Construction

Conductor:

- > Solid copper
- > Soft annealed
- > Diameter 0.9 or 1.4 or 1.8 mm

Insulation:

- > PE (2Y)
- > Naturally coloured
- > Blue marking/tracer core in each layer

Twisting:

- > Cores twisted in concentric layers

Filling:

- > Longitudinal watertight
- > Low capacitance filling compound
- > Drip point > 80 °C

Moisture barrier wrapping:

- > Swellable material
- > Longitudinally applied with overlap

Inner sheath:

- > Laminated with AL tape 0.15 mm
- > One side copolymer coated
- > Bonded with PE sheath
- > Black

Armouring:

- > 1 or 2 layers of galvanized steel tape
- > 0.2 or 0.3 mm
- > Helically applied

Outer sheath:

- > PE (2Y)
- > Black

Characteristics	Unit	0.9 mm	1.4 mm	1.8 mm
Conductor resistance	Ω/km	≤ 28.9	≤ 11.9	≤ 7.2
Insulation resistance	$G\Omega \times \text{km}$	≥ 1.5	≥ 1.5	≥ 1.5
Mutual capacitance at 800 Hz	nF/km	≤ 115 ¹⁾	≤ 145 ²⁾	≤ 145 ²⁾
Operating voltage DC/AC	V	$\leq 600 / \leq 420$	$\leq 600 / \leq 420$	$\leq 600 / \leq 420$
Test voltage at 50 Hz - 1 min				
core/core	V_{rms}	2500	2500	2500
core/screen	V_{rms}	2500	2500	2500

¹⁾ ≤ 120 nF/km for single core in center

²⁾ ≤ 155 nF/km for single core in center

No. of cores	Outer diameter mm	Weight kg/km	Standard length m	Outer diameter mm	Weight kg/km	Standard length m			
							n x 1 x 1.8 mm		
2	13.0	160	1000	-	-	-	-	-	-
4	13.0	170	1000	14.0	240	1000	16.0	300	1000
7	14.0	220	1000	17.0	320	1000	19.0	430	1000
10	17.0	290	1000	18.0	410	1000	21.0	560	1000
14	17.0	300	1000	19.0	490	1000	22.0	680	1000
20	18.0	380	1000	22.0	630	1000	25.0	890	1000
24	20.0	460	1000	23.0	730	1000	27.0	1060	1000
30	20.0	490	1000	24.0	840	1000	29.0	1230	1000
40	21.0	590	1000	27.0	1050	1000	32.0	1560	1000
50	23.0	700	1000	29.0	1280	1000	36.0	1940	1000
60	25.0	800	1000	32.0	1490	1000	38.0	2280	1000
80	26.0	1000	1000	35.0	1920	1000	42.0	2920	1000
100	27.5	1250	1000	39.0	2350	1000	47.0	3630	500
120	32.0	1390	1000	41.0	2730	1000	49.0	4230	500
140	35.0	1650	1000	44.0	3140	1000	53.0	4890	500
160	36.0	1790	1000	46.0	3540	500	55.0	5490	500
180	39.0	2030	1000	49.0	3970	500	59.0	6160	500
200	39.0	2150	1000	50.0	4310	500	60.0	6710	500

SIGNALLING

AJ-2YOF(L)2YDB2Y

HALOGEN FREE & WATERTIGHT

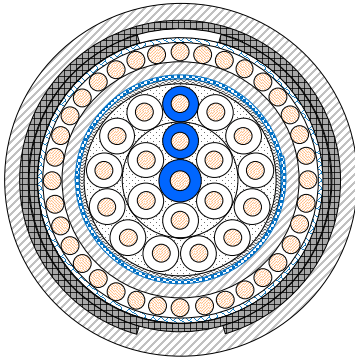

Application

For railway signalling applications, such as wiring of light signals, point machines, balises and axle counters and similar wayside equipment, up to 420 V AC or 600 V DC. Protected against inductive interferences, for example on AC electrified railroads. The cable is longitudinally watertight with stranded copper conductor and steel tape armoring.

Technical data

Design:

- > n x 1 x diameter mm

Bending radius:

- > Flexible: $\geq 20 \times D$
- > Fixed: $\geq 15 \times D$

Temperature range

- > During installation: -10°C to $+60^{\circ}\text{C}$
- > In operations: -40°C to $+60^{\circ}\text{C}$

Material property

- > Halogen free: IEC 60754-1 & 2

Construction

Conductor:

- > Solid copper
- > Soft annealed
- > Diameter 0.9 or 1.4 or 1.8 mm

Insulation:

- > PE (2Y)
- > Naturally coloured
- > Blue marking/tracer core in each layer

Twisting:

- > Cores twisted in concentric layers

Filling:

- > Longitudinal watertight
- > Low capacitance filling compound
- > Drip point $> 80^{\circ}\text{C}$

Moisture barrier wrapping:

- > Water swellable material
- > Longitudinally watertight
- > Applied with overlap

Sheath:

- > Laminated with AL tape 0.15 mm
- > One side copolymer coated
- > Bonded with PE sheath
- > Black

Screen (inductive protection):

- > Concentric screen of copper wires
- > 0.9, 1.2, 1.4 or 1.8 mm
- > 2 layers of galvanized steel tape
- > 0.5 or 0.8 mm

Outer sheath:

- > PE
- > Black

Characteristics	Unit	0.9 mm	1.4 mm	1.8 mm
Conductor resistance	Ω/km	≤ 28.9	≤ 11.9	≤ 7.2
Insulation resistance	$\text{G}\Omega/\text{km}$	≥ 1.5	≥ 1.5	≥ 1.5
Mutual capacitance at 800 Hz	nF/km	≤ 115 ¹⁾	≤ 145 ²⁾	≤ 145 ²⁾
Operating voltage DC/AC	V	$\leq 600/ \leq 420$	$\leq 600/ \leq 420$	$\leq 600/ \leq 420$
Test voltage at 50 Hz - 1 min				
core/core	V_{rms}	2500	2500	2500
core/screen	V_{rms}	2500	2500	2500

¹⁾ ≤ 120 nF/km for single core in center

²⁾ ≤ 155 nF/km for single core in center

No. of cores	Reduction factor class r_k	Outer diameter mm	Weight kg/km	Standard length m	Outer diameter mm	Weight kg/km	Standard length m	Outer diameter mm	Weight kg/km	Standard length m
		n x 1 x 0.9 mm			n x 1 x 1.4 mm			n x 1 x 1.8 mm		
10	600	21.0	650	1000	22.0	790	1000	25.0	1010	1000
20	600	22.0	750	1000	26.0	1090	1000	29.0	1420	1000
30	600	24.0	900	1000	28.0	1350	1000	33.0	1840	1000
50	600	27.0	1190	1000	33.0	1890	1000	39.0	2670	1000
80	600	30.0	1560	1000	32.0	2630	1000	42.0	3770	500
120	600	35.0	2040	1000	44.0	3560	1000	52.0	5210	500
160	600	39.0	2500	1000	49.0	4460	500	58.0	6600	500
200	600	41.0	2930	1000	53.0	5290	500	63.0	7900	250
10	500	21.0	750	1000	22.0	920	1000	25.0	1150	1000
20	500	22.0	870	1000	26.0	1230	1000	29.0	1570	1000
30	500	24.0	1040	1000	28.0	1490	1000	33.0	2010	1000
50	500	27.0	1320	1000	33.0	2080	1000	32.0	2870	1000
80	500	30.0	1740	1000	38.0	2850	1000	46.0	4090	500
120	500	35.0	2230	1000	45.0	3380	500	53.0	5560	500
160	500	39.0	2720	1000	50.0	4790	500	59.0	6980	250
200	500	41.0	3160	1000	54.0	5650	500	64.0	8320	250
30	400	-	-	-	-	-	-	36.0	2690	1000
50	400	-	-	-	36.0	2770	1000	43.0	3800	500
80	400	-	-	-	42.0	3770	500	49.0	5100	500
120	400	-	-	-	48.0	4870	500	56.0	6730	500
160	400	-	-	-	53.0	5880	500	62.0	8290	250
200	400	-	-	-	57.0	6830	500	67.0	9730	250

SIGNALLING

A-2Y2YB2Y

HALOGEN FREE & ARMoured

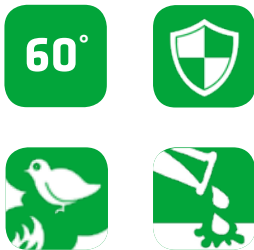
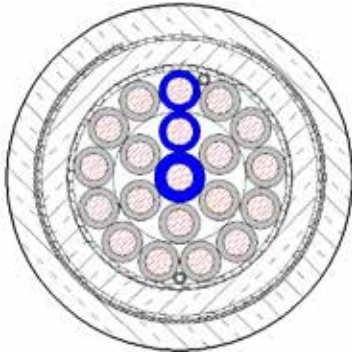

Application

PE insulated and halogen free signalling cable, with cores in concentric layers and armouring. Suitable for railway application directly in the ground or in ducts.

Technical data

Design:

- > $n \times 1 \times \text{diameter mm}$

Bending radius:

- > $\geq 10 \times D$

Temperature range

- > Drung installation: -10°C to $+60^{\circ}\text{C}$
- > In operations: -40°C to $+60^{\circ}\text{C}$

Standard

- > PH 416.0115 V1.1

Material property

- > Halogen free: IEC 60754-1 & 2

Construction

Conductor:

- > Solid copper
- > Soft annealed
- > Diameter 0.9 or 1.4 or 1.8 mm

Insulation:

- > PE
- > Natural coloured
- > Blue marking/tracer core in each layer

Twisting:

- > Cores twisted in concentric layers
- > 2 perforated pilot cores if ≥ 14 cores
- > 0.5 mm

Wrapping:

- > Non-hygroscopic foil

Inner sheath:

- > PE
- > Black

Armouring:

- > 1 layers of galvanized steel tape 0.2-3 mm
- > 2 layers of galvanized steel tape 0.1 mm
- > Helically applied

Outer sheath:

- > PE
- > Black

Characteristics	Unit	0.9 mm	1.4 mm	1.8 mm
Conductor resistance	Ω/km	≤ 28.9	≤ 11.9	≤ 7.2
Insulation resistance	$G\Omega \times \text{km}$	≥ 10	≥ 10	≥ 10
Mutual capacitance at 800 Hz	nF/km	≤ 115 ¹⁾	≤ 145 ²⁾	≤ 145 ²⁾
Operating voltage DC/AC	V	$\leq 600 / \leq 420$	$\leq 600 / \leq 420$	$\leq 600 / \leq 420$
Test voltage at 50 Hz - 1 min				
core/core	V_{rms}	2500	2500	2500
core/screen	V_{rms}	2500	2500	2500

¹⁾ ≤ 120 nF/km for single core in center

²⁾ ≤ 155 nF/km for single core in center

No. of cores	Outer diameter mm	Weight kg/km	Standard length m	Outer diameter mm	Weight kg/km	Standard length m	n x 1 x 1.8 mm		
							Outer diameter mm	Weight kg/km	Standard length m
							n x 1 x 0.9 mm		
							n x 1 x 1.4 mm		
4	14.0	190	1000	14.0	190	1000	15.5	250	1000
7	15.5	260	1000	15.5	260	1000	17.0	350	1000
10	18.0	340	1000	18.0	340	1000	20.0	470	1000
14	19.0	420	1000	19.0	420	1000	21.0	600	1000
20	21.0	550	1000	21.0	550	1000	24.0	800	1000
24	22.0	360	1000	22.0	630	1000	26.0	910	1000
30	23.0	750	1000	23.0	750	1000	27.0	1100	1000
40	25.0	940	1000	25.0	940	1000	30.0	1400	1000
50	28.0	1140	1000	28.0	1140	1000	-	-	-
60	30.0	1320	1000	30.0	1320	1000	-	-	-

SIGNALLING & AXLE COUNTER

AJ-2Y(L)2YDB2Y

ARMoured & INTERFERENCE PROTECTED

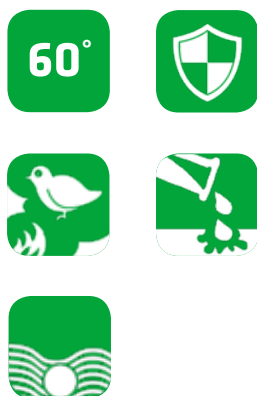
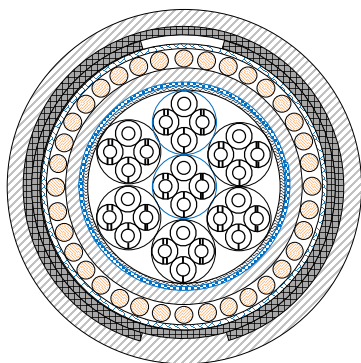

Application

For railway signalling application for transmission of low frequent signal through symmetric circuits, for example axle counter devices and similar wayside equipment. Protected against inductive interferences, for example on AC electrified railroads.

Protected against inductive interferences, for example on AC electrified railroads. The cable is star quad stranded with steel tape armouring.

Technical data

Design:

- > n x 4 x diameter mm

Bending radius:

- > $\geq 10 \times D$

Temperature range

- > Upon installation: - 10°C to + 60°C
- > In operations: - 40°C to + 60°C

Standard

- > PH 416.0115 V1.1

Material property

- > Halogen free: IEC 60754-1 & 2

Construction

Conductor:

- > Solid copper
- > Soft annealed
- > Diameter 0.9 or 1.4 mm

Insulation:

- > PE (2Y)
- > Natural colour with black ring marketing
- > Quad in each layer carry open blue helix

Twisting:

- > Cores twisted to star quads
- > Quads laid up in concentric layers
- > 2 perforated pilot cores if ≥ 7 quads

Wrapping:

- > SNon-hygroscopic plastic tape

Moisture barrier:

- > Laminated sheath
- > Aluminium tape 0.15 mm
- > One side copolymer coated
- > Bonded with inner sheath

Inner sheath:

- > PE
- > Black

Screen:

- > Copper wires 1.9, 1.2, 1.4 or 1.8 mm
- > Helically applied

Armouring:

- > Two layers of galvanized steel tape
- > 0.5 or 0,8

Outer sheath:

- > PE (2Y)
- > Black

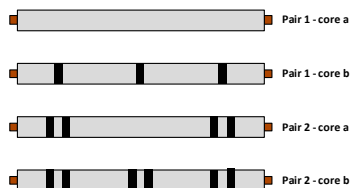

Characteristics	Unit	0.9 mm	1.4 mm
Conductor loop resistance	Ω/km	≤ 56.6	≤ 23.4
Insulation resistance	$\text{G}\Omega/\text{km}$	≥ 10	≥ 10
Mutual capacitance at 800 Hz	nF/km	≤ 45 ¹⁾	≤ 45 ¹⁾
Capacitance unbalance at 800 Hz			
k_1 (100 % / 50 % of all values)	$\text{pF}/500 \text{ m}$	$\leq 650 / \leq 150$	$\leq 650 / -$
k_{9-12} neighboured quads	$\text{pF}/500 \text{ m}$	$\leq 500 / \leq 150$	$\leq 500 / -$
k_{9-12} over-neighboured quads	$\text{pF}/500 \text{ m}$	≤ 150	≤ 150
$e_{a1/2}$	$\text{pF}/500 \text{ m}$	≤ 1300	≤ 1300
Far-end crosstalk attenuation at 90 kHz			
100 % / 80 % of all values	dB/km	$\geq 58 / \geq 62$	$\geq 33 / -$
Attenuation at 90 kHz	dB/km	≤ 3.3	≤ 2.6
Test voltage at 50 Hz - 1 min			
core/core	V_{rms}	2500	2500
core/screen	V_{rms}	2500	2500

¹⁾ $\leq 52 \text{ nF}/\text{km}$ for $1 \times 4 \times \emptyset$ and for central quads, where 1st layer consist only of one quad, as well as in the outer layer of armoured cables.

No. of quads	Reduction factor class r_k	Outer diameter mm	Weight kg/km	Standard length m	Outer diameter mm		Standard length m
					$n \times 4 \times 0.9 \text{ mm}$ (H45)	$n \times 4 \times 1.4 \text{ mm}$ (H45)	
3	600	21.0	800	1000	-	-	-
5	600	23.0	1010	1000	-	-	-
10	600	28.0	1430	1000	-	-	-
20	600	35.0	2130	1000	-	-	-
30	600	40.0	2800	1000	-	-	-
40	600	45.0	3380	1000	-	-	-
3	500	-	-	-	25.0	1350	1000
5	500	-	-	-	29.0	1760	1000
10	500	-	-	-	37.0	2620	1000
20	500	-	-	-	47.0	4040	500
30	500	-	-	-	54.0	5330	500
40	500	-	-	-	61.0	6550	500
5	400	-	-	-	31.0	2470	1000
10	400	31.0	2250	1000	39.0	3610	1000
20	400	38.0	3240	1000	49.0	5260	500
30	400	43.0	4080	500	56.0	6690	500
40	400	48.0	4800	500	63.0	8070	250

CONTROL

MCCMK-HF EMC 0.6/1 kV

HALOGEN FREE & EMC SCREENED



Application

Low smoke halogen free and EMC protected cable with 100% dense copper screen with low coupling impedance that fulfills the EMC-directive. For fixed installation indoor and outdoors, in pipes, trays, non-vibrated cement and directly in the ground.

Technical data

Rated voltage:

- > 0.6/1 kV

Test voltage:

- > 4,000 V

Tensile strength:

- > Max. 50 x A N/mm²

Bending radius:

- > Fixed 10 x D

Temperature range

- > Max. conductor temperature: +90°C
- > Short circuit temperature: +250°C
- > Lowest temp. at installation: -15°C
- > Below 0°C exercise caution

Standard & Directive

Standard:

- > HD 604-5D
- > IEC 60502-1
- > EN 50267

Directive:

- > Fulfills LVD, RoHS and REACH

Construction

Conductor:

- > Round copper wires
- > Annealed
- > < 6 mm²: Solid
- > 10-35 mm²: Stranded
- > 50-240 mm²: Sector-shaped

Insulation:

- > XLPE compound

Core colouring:

- > 3-core: brown, black, gray
- > 4-core: blue, brown, black, gray

Screen:

- > Copper tape
- > Concentric screen of copper wires

Outer sheath:

- > Halogen free compound
- > Black

Material property

- > Flame retardant: IEC 60332-1-2
- > Halogen free: IEC 60754-1 & 2
- > Smoke density: IEC 61034
- > EMC: IEC/EN 6100

Conductor cross-section mm ²	Outer diameter mm	Weight kg/km	Max. DC resistance of phase conductor at 20°C Ω/km	Standard length m	Prysmian article no.
3 x 25/16	23	1,100	0.727	500 - K11	0600230
3 x 50/25	27	1,900	0.387	500 - K11	0600236
3 x 95/50	35	3,500	0.193	500 - K14	0600234
3 x 120/70	38	4,300	0.153	500 - K16	0600235
3 x 150/70	42	5,200	0.124	500 - K16	0600238
3 x 185/95	47	6,500	0.099	500 - K20	0600237
3 x 240/120	51	8,400	0.075	500 - K22	0600239
4 x 25/16	26	1,400	0.727	500 - K11	0607644
4 x 35/16	29	1,800	0.524	500 - K12	0607641
4 x 50/25	31	2,300	0.387	500 - K14	0607640
4 x 70/35	34	3,200	0.268	500 - K14	0607642
4 x 95/50	39	4,300	0.193	500 - K16	0607643
4 x 120/70	43	5,400	0.153	500 - K19	0607651
4 x 150/70	46	6,600	0.124	500 - K20	0607647
4 x 185/95	53	8,300	0.099	500 - K22	0607645
4 x 240/120	58	11,000	0.075	500 - K26	0607646

Conductor cross-section mm ²	Pulling force with eye Max. kN	Max. short circuit current PE conductor kA	Inductance mH/km	Operating capacitance uF/km	Current rating in free air at 90°C A
3 x 25/16	3.8	2.4	0.26	0.35	135
3 x 50/25	5.3	4.0	0.26	0.40	200
3 x 95/50	7.5	6.7	0.25	0.45	310
3 x 120/70	10.5	9.6	0.24	0.50	360
3 x 150/70	14.3	9.6	0.24	0.50	410
3 x 185/95	18.20	12.0	0.24	0.50	470
3 x 240/120	20	14.8	0.23	0.55	560
4 x 25/16	5	2.4	0.28	0.30	135
4 x 35/16	7	2.4	0.28	0.32	165
4 x 50/25	10	4.0	0.28	0.35	200
4 x 70/35	14	5.2	0.27	0.40	250
4 x 95/50	19	6.7	0.27	0.42	310
4 x 120/70	20	9.6	0.26	0.44	360
4 x 150/70	20	9.6	0.26	0.46	410
4 x 185/95	20	12.0	0.26	0.49	470
4 x 240/120	20	14.8	0.25	0.52	560

CONTROL

MCCMO-HF C-PRO 450/750 V

HALOGEN FREE & EMC PROTECTED



Application

EMC-protected cable for the control, measuring and signal circuits of electrical equipment for fixed surface and flush-mounted installations, indoors, outdoors and also underground - specially in places where the cable is exposed to vibration.

Technical data

Rated voltage:

- > 450/750 V

Test voltage:

- > 2,500 V

Bending radius::

- > During installation: 10 x D
- > Fixed: 8 x D

Temperature range

- > In operations: max. +90°C
- > Short circuit temperature: +250°C
- > Lowest temp. at installation: -15°C

Standard & Directive

Standard:

- > HD 627 7B2

Directive:

- > Fulfills RoHS and REACH

Approval:

- > CPR class: Cca-s1d1a1

Construction

Conductor:

- > Round copper wires
- > Annealed and solid
- > Acc. to IEC 60228 class 1.

Insulation:

- > HFFR
- > White
- > Black numbering

Wrapping:

- > Halogen free

Screen:

- > Helix of copper wires
- > Counter helix of copper wires or tape
- > Min. cross-section area 6 mm²

Outer sheath:

- > Halogen free polymer
- > Black

Material property

- > Halogen free: IEC 60754
- > Flame retardant: IEC 60332-1 & 3
- > Smoke density: EN 60134

Content is subject to changes acc. to current product development and or any changes to standards.

Conductor cross-section mm ²	Outer diameter mm	Weight kg/km	Standard delivery m	Prysmian EAN no.
7 x 1.5	14.1	340	1000 - K9	
12 x 1.5	15.9	449	500 - K8	
19 x 1.5	17.3	481	1000 - K11	
7 x 2.5	20.0	666	1000 - K12	
12 x 2.5	19.7	647	500 - K9	

CONTROL

HIKA 300/500 V

ARMOURED

Application

Halogen free light installation cable applicable for areas that require extra mechanical protection. Fulfills requirements for rodent protection. Suitable for indoor and outdoor installation in pipes, trays, directly in the ground or in non-vibrated cement. Insulation must be protected from UV-light.

Technical data

Rated voltage:

- > 300/300 VC

Test voltage:

- > 2,000 V

Bending radius:

- > 10 x D

Temperature range

- > Max. conductor temperature: +70°C
- > Short circuit temperature: +250°C
- > Max. installation temperature: -20°C
- > Min. operating temperature: -40°C

Standard & Directive & Approval

Standard:

- > Partially adapted to DS 2393-3

Directive:

- > Fulfills LVD, RoHS & REACH

Approval:

- > CPR class: Eca
- > DoP no. - see table

Construction

Conductor:

- > Round copper wires
- > Solid or stranded
- > Class 1. and 2. acc. to IEC 60228

Insulation:

- > XLPE

Core colouring:

- > 4-core: blue, brown, black, grey
- > 7-core: blue, brown, black, grey, white, red, black

Filling:

- > Halogen free compound

Armouring:

- > Galvanized steel band
- > Coverage 100%

Outer sheath:

- > Halogen free compound
- > Grey

Material property

- > Halogen free: IEC 60754-1
- > Acidity: IEC 60754-2
- > Flame retardant: IEC 60332-1
- > Smoke density: IEC 61034
- > Current load acc. to SB2006:6

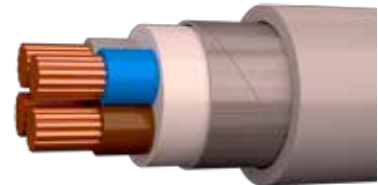

Content is subject to changes acc. to current product development and or any changes to standards.

Conductor cross-section mm ²	Outer diameter mm	Weight kg/km	Standard length m	DoP no.	Prysmian EAN no.
4 x 4	12.8	307	500	1003090	8711401010025
4 x 10	18.2	700	500	1003932	8711401009890
4 x 16	21.0	1000	500	1003089	8711401009968
7 x 1.5	11.8	236	500	1003095	8711401010629
7 x 2.5	13.0	312	500	1003096	8711401010643
7 x 2.5	13.0	312	2000	1003096	8711401010728
7 x 4	14.9	435	500	1003097	8711401010933

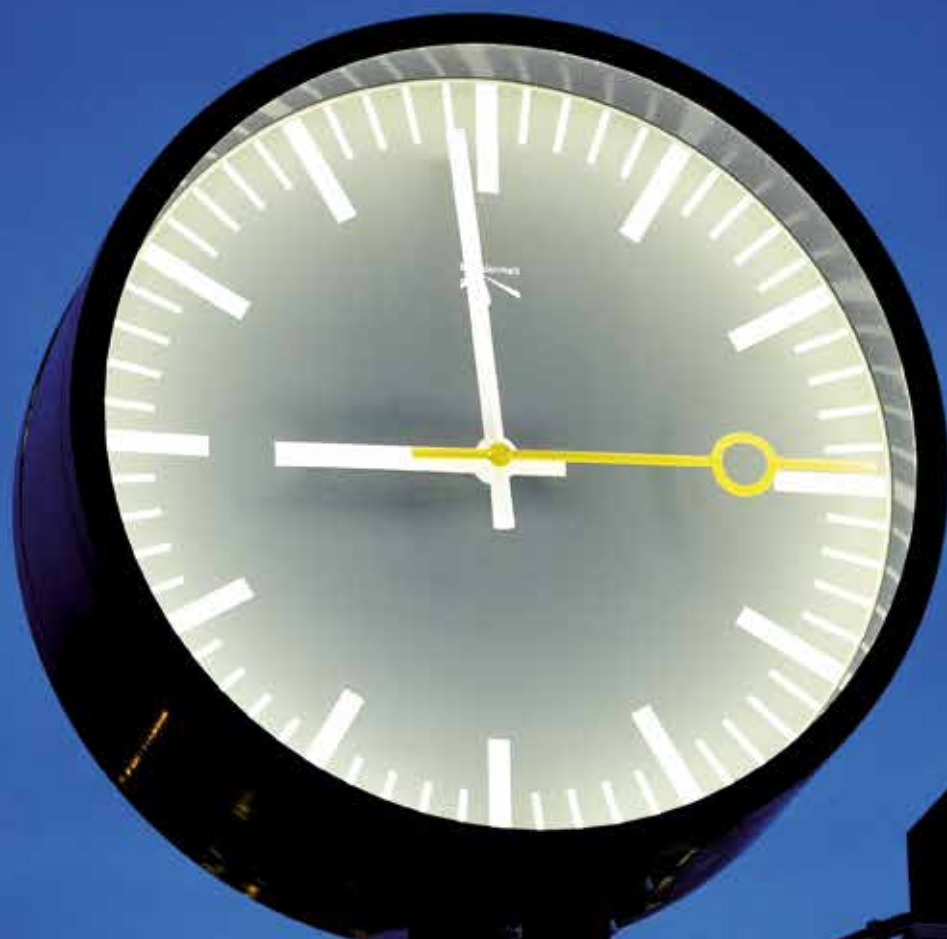

21.10

Til

Helsingør



Klampenborg Skodsborg Vedbæk Rungsted Kyst Kokkedal
Nivå Humlebæk Espergærde Snekkersten

Kort tog

COMMUNICATION

A-DQ2Y

DUCT INSTALLATION VIA BLOWING TECHNIQUE

Application

Optical cable designed for duct installation by blowing technique. Core is dry with swellable materials to prevent longitudinal water penetration.

Technical data

Tensile strength:

- > 7,000 N

Crush:

- > 1,500 N

Impact:

- > 1J, 3 impacts, R=300

Torsion:

- > 5 cycles

Repeated bending:

- > 4 x D, 25 cycles

Kink:

- > No kink at bending radius 20 x OD

Bending radius:

- > Loaded: 20 x D
- > Unloaded: 15 x D

Water penetration:

- > No water penetration 1 m/24 hours

Temperature range

- > Storage: - 40°C to + 70°C
- > Installation: - 5°C to + 55°C
- > Operation: - 30°C to + 60°C

Construction

Central strength member (CSM):

- > Glass fibres
- > Reinforced plastic material, FPR rod

Loose tube:

- > Thermoplastic tubes
- > 6-12 fibres in each

Tube colours:

- > 12 fibres - red tube
- > 24 fibres - red and green tube
- > 1st. tube red, 2nd. tube green, rest white

Fibre colours:

- > 1 red, 2 green, 3 blue, 4 yellow, 5 white
- > 6 grey, 7 brown, 8 violet, 9 turquoise
- > 10 black, 11 orange, 12 pink

Filler:

- > Thermoplastic rod, when needed

Identification:

- > Thread

Stranding:

- > Loose tubes
- > "SZ" stranded around the CSM

Water blocking:

- > Swellable material
- > Longitudinal watertight
- > Dry core

Outer sheath:

- > PE, with min. 2% carbon black
- > Black

Standard

- > IEC 60794-3-10
- > IEC 60794-1-2

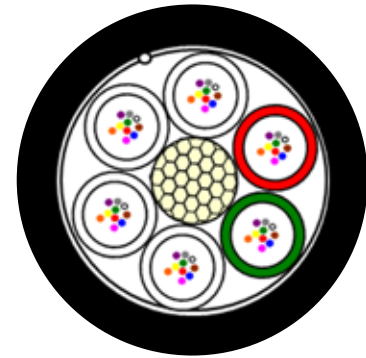

Content is subject to changes acc. to current product development and or any changes to standards.

Fibre count	Number of fillers	Tube diameter mm	CMS enlargement dia. mm	Sheath thickness mm	Outer diameter mm	Weight kg/km
24	2 x 12	1.55	1.6	0.5	5.7±0.2	30
48	4 x 12	1.55	1.6	0.5	5.7±0.2	30

COMMUNICATION

COMPACT MULTI-FUNCTION JOINT

144 FIBRE CAPACITY & IP68



70°



Application

The Compact Multi-function Joint (CMJ) is for jointing optical fibre cables. The joint is ideal for use as a Cable Chamber Joint, Track Joint, Spur Joint or Distribution Joint due to its capacity and compact size.

It has a maximum capacity of 144 fibres. The splice trays are factory fitted and each tray can accommodate up to 12 spliced fibres.

A multi-functional bracket can be supplied with the joint which enables wall or pole mounting of the joint, vertically or horizontally.

The joint has four circular ports for mechanical entry glands, one oval port for heat shrink or mechanical entry and two additional small circular ports also for heat shrink entry.

A kit is supplied with following items:
A base, cap, clamp, O seal, fibre routing management, two tube retainers, four tube retainer covers and one loop storage basket.

Order no.

- > Example: CMJ-H-M-X-Y-D
- > Additional kits order separately

Standard

- > Closure sealing: IP68
- > Optical tested: 1310, 1550, 1625 nm
- > Change temperature: IEC 61300-2-22
- > Dry sealing: BS EN 60068-2-2
- > Damp heat: IEC 60068-2-3
- > Vibration: IEC 61300-2-1
- > Torsion: IEC 61300-2-5
- > Bending: IEC 61300-2-37
- > Impact: IEC 61300-2-12
- > Cable retention: IEC 61300-2-4
- > Crush resistance: IEC 61300-2-10

Construction

Joint:

- > Ultra compact design
- > Cap and base of GF polypropylene
- > Trays of FR ABS
- > Integrated loop storage basket
- > Multi-way entry glands available

Input manifold:

- > Route management of fibres

Splice tray capacity:

- > 12 single element trays - 96 fibres
- > 12 single circuit double trays - 144 fibres
- > 1.3 mm splice protectors
- > Splice trays hinge upwards
- > Heat shrinkable

Entry ports:

- > 4 circular, 7-20 mm
- > 1 oval, 7-21 mm - heat shrink
- > 2 emergency, 4-12 mm

Dimensions:

- > Size: H 290 x W 231 x D 164 mm
- > Weight: 1.9 kg

Technical data

Bending radius:

- > Positive bend managed to 20 mm

Temperature range

- > In operation: - 40°C to + 70°C

CMJ type	Seal type	Mechanical gland type	Pressure test valve	Mounting type	No. splice protectors
CMJ Single element	X - none H - heat shrink A - mechanical 5-7 mm B - mechanical 7-9 mm C - mechanical 9-11 mm	X- none C - single 7-20 mm E - 8 way 2-3 mm flat M - 4 way 5-7 mm	X - no valve Y - with valve	X - no bracket Y - with bracket	X - none A - 1 pack x 12 B - 2 pack x 12 C - 3 pack x 12 D - 1 pack x 50 E - 2 pack x 50 F - 3 pack x 50
CMJ Single circuit	D - mechanical 11-13 mm E - mechanical 13-14 mm				

Kit description	Kit order number				
Oval port heat shrink	XJTSC01756				Pole/ wall mounting bracket XJTSC00136
Oval port mechanical	XJTSC02028 (5-7 mm)	XJTSC02029 (7-9 mm)	XJTSC02030 (9-11mm)	XJTSC02031 (11-13mm)	XJTSC01896 (13-15mm)
Circular port	Single entry gland XJTSC01754	MS 4-ways entry gland XJTSC01755	MS 8-ways flat drop gland XJTSC01878	Emergency port entry XkTSC00401	
Accessories	Optical splitters 16 pcs. XSPSG00004	Optical splitters 32 pcs. XSPSG00005	HS splice protectors 12 pcs. XKTSC01284	HS splice protectors 50 pcs. XPESC00057	Silicone grease 5 pcs. XBFSC00260

COMMUNICATION

SRS3000 SPLICE & PATCH SHELF

19" MODULAR 1U



60°

Application

This type of splice and patch shelf is a modular unit available in a variety of configurations for integration in to 19" and ETSI racks, street side or wall mounted cabinets.

The product consists of a metal chassis, a plastic light weight splice and patch module and a cable anchoring system.

The product has a capacity of up to 48 fibres in a 1U unit for SC and LC type connectors, and up to 24 fibres for FC, ST and E2000 type connectors.

The panel has in-built fibre management to ensure the product is installed correctly and the same every time by installers.

The shelf is fully compatible with all optical cable types, with blown fibre tube cables and can be configured to hold optical devices (i.e. splitters & WDM's) on request.

Temperature range

- > In operation: - 20°C to + 60°C

Standard

Optical:

- > Tested at 1310, 1550 and 1625 nm

Dry heat:

- > BS EN 60068-2-2 Test Bb

Optical:

- > IEC 60068-2-3: 1969

Change temperature:

- > IEC 60068-2-14: 1984

Vibration:

- > IEC 60068-2-6: 1995

Shock:

- > IEC 60068-2-27: 1987

Construction

Shelf:

- > Steel, modular shelf design
- > Drop down front panel
- > Labeling
- > Easy upgrade from 12 to 48 fibres
- > For 19" rack systems
- > Wall mountable

Splice & patch modules:

- > High impact polystyrene
- > Detachable lid with screws
- > Pivots outward for easy access

Splice & patch capacity:

- > 48 SC or LC connectors, 2 mm
- > 24 FC, ST or E2000 connectors

Dimensions:

- > Size: W 480 x D 245 x H 44.5 mm
- > Weight: 2.4 kg

Technical data

Bending radius:

- > Positive bend managed to 30 mm

Part number	Connector type	Fibre type	Adaptor type	No of fibres	Upgradeable	Part number
SRS1-002	FC/UPC	S/mode	Simplex	12	Yes to 24	XSRSC00288
SRS1-003	FC/UPC	S/mode	Simplex	24	No	N/A
SRS1-004	FC/APC	S/mode	Simplex	12	Yes to 24	XSRSC00291
SRS1-005	FC/APC	S/mode	Simplex	24	No	N/A
SRS1-006	FC	62.5/125	Simplex	12	Yes to 24	XSRSC00289
SRS1-007	FC	62.5/125	Simplex	24	No	N/A
SRS1-008	FC	50/125	Simplex	12	Yes to 24	XSRSC00290
SRS1-009	FC	50/125	Simplex	24	Yes to 24	N/A

Part number	Connector type	Fibre type	Adaptor type	No of fibres	Upgradeable	Part number
SRS1-010	SC/UPC	S/mode	Simplex	12	Yes to 24	XSRSC00292
SRS1-011	SC/UPC	S/mode	Simplex	24	No	N/A
SRS1-012	SC/UPC	S/mode	Duplex	12	Yes to	24 XSRSC00296
SRS1-013	SC/UPC	S/mode	Duplex	24	No	N/A
SRS1-014	SC/UPC	S/mode	Quad *	24	Yes to 48	XSRSC00344
SRS1-015	SC/UPC	S/mode	Quad *	48	No	N/A
SRS1-016	SC/APC	S/mode	Simplex	12	Yes to 24	XSRSC00295
SRS1-017	SC/APC	S/mode	Simplex	24	No	N/A
SRS1-018	SC/APC	S/mode	Duplex	12	Yes to 24	XSRSC00299
SRS1-019	SC/APC	S/mode	Duplex	24	No	N/A
SRS1-020	SC/APC	S/mode	Quad *	24	Yes to 48	XSRSC00345
SRS1-021	SC/APC	S/mode	Quad *	48	No	N/A
SRS1-022	SC	62.5/125	Simplex	12	Yes to 24	XSRSC00293
SRS1-023	SC	62.5/125	Simplex	24	No	N/A
SRS1-024	SC	62.5/125	Duplex	12	Yes to 24	XSRSC00297
SRS1-025	SC	62.5/125	Duplex	24	No	N/A
SRS1-026	SC	62.5/125	Quad *	24	Yes to 48	XSRSC00346
SRS1-027	SC	62.5/125	Quad *	48	No	N/A
SRS1-028	SC	50/125	Simplex	12	Yes to 24	XSRSC00294
SRS1-029	SC	50/125	Simplex	24	No	N/A
SRS1-030	SC	50/125	Duplex	12	Yes to 24	XSRSC00298
SRS1-031	SC	50/125	Duplex	24	No	N/A
SRS1-032	SC	50/125	Quad *	24	Yes to 48	XSRSC00347
SRS1-033	SC	50/125	Quad *	48	No	N/A

Part number	Connector type	Fibre type	Adaptor type	No of fibres	Upgradeable	Part number
SRS1-034	LC/UPC	S/mode	Duplex	24	Yes to 48	XSRSC00300
SRS1-035	LC/UPC	S/mode	Duplex	48	No	N/A
SRS1-036	LC/UPC	S/mode	Quad	24	Yes to 48	XSRSC00304
SRS1-037	LC/UPC	S/mode	Quad	48	No	N/A
SRS1-038	LC/APC	S/mode	Duplex	24	Yes to 48	XSRSC00303
SRS1-039	LC/APC	S/mode	Duplex	48	No	N/A
SRS1-040	LC/APC	S/mode	Quad	24	Yes to 48	XSRSC00307
SRS1-041	LC/APC	S/mode	Quad	48	No	N/A
SRS1-042	LC	62.5/125	Duplex	24	Yes to 48	XSRSC00301
SRS1-043	LC	62.5/125	Duplex	48	No	N/A
SRS1-044	LC	62.5/125	Quad	24	Yes to 48	XSRSC00302
SRS1-045	LC	62.5/125	Quad	48	No	N/A
SRS1-046	LC	50/125	Duplex	24	Yes to 48	XSRSC00305
SRS1-047	LC	50/125	Duplex	48	No	N/A
SRS1-048	LC	50/125	Quad	24	Yes to 48	XSRSC00306
SRS1-049	LC	50/125	Quad	48	No	N/A

4. Communi- cation

Content is subject to changes acc. to current product development and or any changes to standards.

Part Number	Connector type	Fibre type	Adaptor type	No. of fibres	Upgradable	Part Number
SRS1-050	E2000/UPC	S/mode	Simplex	12	Yes to 24	XSRSC00308
SRS1-051	E2000/UPC	S/mode	Simplex 24	No	N/A	
SRS1-052	E2000/APC	S/mode	Simplex	12	Yes to 24	XSRSC00311
SRS1-053	E2000/APC	S/mode	Simplex	24	No	N/A
SRS1-054	E2000	62.5/125	Simplex	12	Yes to 24	XSRSC00309
SRS1-055	E2000	62.5/125	Simplex	24	No	N/A
SRS1-056	E2000	50/125	Simplex	12	Yes to 24	XSRSC00310
SRS1-057	E2000	50/125	Simplex	24	No	N/A

Part number	Connector type	Fibre type	Adaptor type	No of fibres	Upgradeable	Part Number
SRS1-058	ST/UPC	S/mode	Simplex	12	Yes to 24	XSRSC00341
SRS1-059	ST/UPC	S/mode	Simplex	24	No	N/A
SRS1-060	ST	62.5/125	Simplex	12	Yes to 24	XSRSC00342
SRS1-061	ST	62.5/125	Simplex	24	No	N/A
SRS1-062	ST	50/125	Simplex	12	Yes to 24	XSRSC00343
SRS1-063	ST	50/125	Simplex	24	No	N/A

Kit description	Kit order number	Kit order number
Heat shrink splice protectors	XKTSC00050 (pack of 12)	XPESC00053 (pack of 50)
Chrimp splice protectors	XKTSC00079 (pack of 12)	XKTSC00078 (pack of 50)
Splice protector holders	XSRSC00358 (pack of 10) Crimp splice	XKTSC00377 (pack of 10) Heat shrink
ETSI conversion brackets	XKTSC00171 Grey	
Rear mounting brackte	XSRSC00361	

myldretid

København H

DSB

02 22 42

uden stop Humlebæk-Rungsted Kyst Rungsted

ma-fr 6.42-8.22

aften

Malmö C 

02 22 42

til Kbh./Kastrup alle dage 20.02- 0.02
til Malmö alle dage 20.02-23.22

nat

Malmö C 

18

nat efter fr og lø 0.18-3.18

Railway Main Line Cables

Cables with reduction factor

On electrified tracks which are operated using alternating current or under high-voltage power lines, parallel laid railway cables are exposed at the same time to the influence of electromagnetic fields. These electromagnetic fields induce current in the cables, which can lead to disturbances and destruction of the equipment connected to them as well as present a hazard to life and limb. In order to reduce this influence to a non-hazardous level, the cables are provided with a metallic shield according to their cross-section. This shield has to be earthed on both sides of the cable.

The measure of quality used to shield cables in railway applications is referred to as the reduction factor. The reduction factor is the ratio of induced tension with shielding to the induced tension without shielding. A reduction factor of 1 would mean "no shielding effect". A reduction factor of 0.5, for example, would mean a reduction of the induced tension by one half.

The effect of shielding of the materials used (copper, steel, aluminium, etc.) is dependent on the conducting cross-section of shielding as well as the frequency of the interfering signal.

Depending upon the local circumstances, the cable design and hence the resultant reduction factor can be optimised to best match the expected field strength along the railway track. A typical description for the request for a cable protected against inductive interference shall include disturbing frequency and field intensity as well as the requested reduction factor. For example:

- Reduction factor < 0.5 at 16.7 Hz in the range of 80 – 150 V/km or
- Reduction factor < 0.3 at 50 Hz in the range of 80 – 250 V/km.

The tension induced in the cable increases with the length the cable is exposed to the electrical field. A cable which is exposed over a length of 2000 m to the field can require a lower (better) reduction factor than the same cable, which is only exposed to the induced field over a length of 1000 m.

The calculation of the actually required reduction factor is very complicated and depends on a multitude of different parameters:

- Distance of the cable to be shielded from the interfering cable (overhead line...),
- Type of installation (underground, in conduits, on the ground...),
- Characteristics of the ground,
- etc.

A respective calculation of the required reduction factor can only be carried out by experts. The cable manufacturer then develops the correct cable design based on the given factors.

As a supplier of cables for railway applications and development partners of well-known European railway operators of long standing, Prysmian offers an extensive portfolio of different cables with reduction factor. Upon request we shall be pleased to develop the right cable design for a customer's purposes.

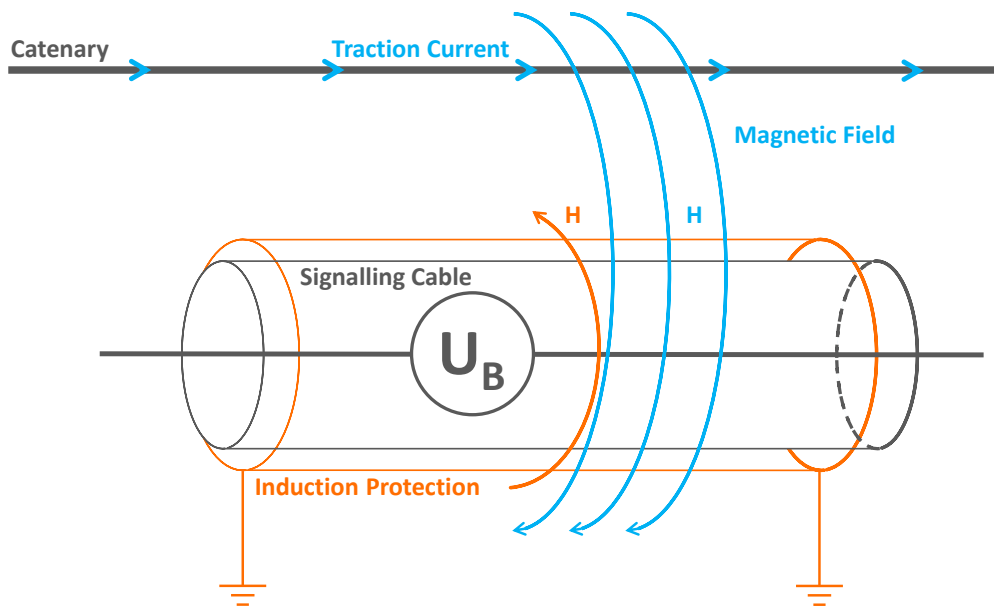

Picture: Magnetic field compensation by inductive protection



Picture: Cable AJ-2Y(L)2YDB2Y 10x4x1.4 mm S (H45) rk 600 of Deutsche Bahn with protection against inductive interference

Railway Main Line Cables

Requirements for fire characteristics of cable installations in tunnels or stations

Prysmian Group provides a complete product range of cables and circuits for the railway infrastructure sector. We also take into consideration the special requirements needed for laying cables in closed environments.

Most railway infrastructure operators specify cables with a black polyethylene (PE) outer sheath for use in the open air. PE is extremely robust and resistant, has very good UV resistance due to the black colouring and guarantees a cable life of about 35 years. PE is halogen-free and burns with low smoke emissions without releasing toxic gases.

In closed areas and narrow spaces, in applications such as tunnels or railway stations, the requirements for the cables are very demanding.

Even though PE is halogen-free and burns with low smoke, it is not recommended for such applications. PE is not self-extinguishing and contributes to further propagation of fire. The fire can penetrate into adjacent rooms and cause more damage. Cables with PVC outer sheath are no alternative either. Although PVC is flame retardant and usually self-extinguishing, it burns producing dark soot and releases toxic gases.

The ideal materials combine the advantages of PE and PVC, are halogen free, produce little smoke, and are flame retardant and self-extinguishing. Such materials are manufactured, refined and improved in Prysmian's material laboratories. Known halogen-containing materials are, for example, chloroprene rubber (CR), ethylene tetrafluoroethylene (ETFE), perfluoroethylene propylene (FEP) or polyvinyl chloride (PVC).

Halogen free materials are, among others, silicone rubber (SIR), polyamide (PA), ethylene propylene polymers (EPR), thermoplastic elastomers (PE) or polyethylene (PE).

There are European and international standards regarding the unique and comparable classification of flammability properties of cables. We want to briefly introduce to you the most important test procedures.

Fire testing

EN/IEC 60332-1

(Tests on electric and optical fibre cables under fire conditions: test for vertical flame propagation for single insulated wire or cable)

The flame propagation is tested according to IEC 332-1 on a single cable. A vertical sample of cable about 600 mm in length is exposed to a flame for 60 s and/or 120 s in an area 100 mm above the lower end with a 1 kW Bunsen burner. After removing the burner, the flame must self-extinguish. The zones of the cable damaged by the flame should not reach to the upper end of the cable. The flaming time is dependant on the diameter of the cable.

Comparable tests are DIN VDE 0482-332-1-2, EN 50265-2-1, NF C 32-070 C2, BS 4066-1.



EN/IEC 60332-3

(Tests on electric and optical fibre cables under fire conditions: test for vertical flame spread of vertically mounted bunched wires or cables)

The test for the spread of the flame with an array of several cables, i.e. a bunch of cables, is normally carried out according to IEC 332-3 (EN 50266-2, test method A, B, C or D – for use of different volumes of non-metallic materials).

The test specimens, mounted in a vertical frame, are exposed to a flame over a length of 3600 mm starting in the lower section using a special burner with a high output. During and/or after exposure to the intensive flame for 20 and/or 40 minutes, the cables may not continue to burn to their upper end.

Comparable tests are DIN VDE 0482-266-2-4, EN 50266, NBN C30-004 Cat. F2, BS 4066-3.



Railway Main Line Cables

IEC 331

(Cable with insulation integrity)

A horizontal cable sample is exposed to a flame over a width of 1200 mm with a flame temperature of at least 750 °C for a recommended duration of at least 90 minutes. The cable is connected up electrically and under tension. During flaming and a cooling down time of an additional 15 minutes, no short circuiting or interruption of the current may arise.

Comparable tests are EN 50200, EN 50263, NF C 32070 CR1, BS 6287.

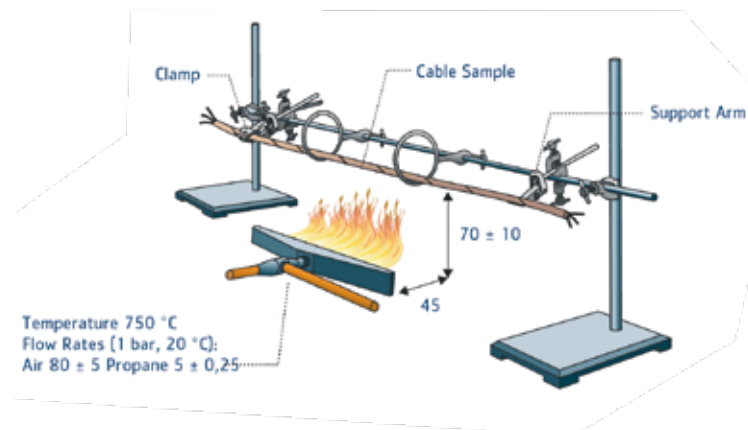

DIN 4102 part 12

(Cable with functional integrity – system testing of cable and the cable mounting system)

This test is very extensive. As it is a test of the system which includes the cable and the cable mounting system, the product to be tested is completely walled into a closed space. The cables are connected up electrically and are kept under tension during the test. The entire room is set alight with a defined temperature unit curve. After at least 30 minutes flame exposure, neither short-circuiting or interruption of circuit may arise. It is extremely difficult to pass the test, as the cable mounting system has a considerable influence on the result. Cable clips, ducts or conductors exert mechanical loads on the cable, as the material changes during flaming: cable ducts start to bend through the load exerted by the cable and the originally smooth cable suddenly hangs down at several points. This mechanical change of position of the burned cable can lead to interruption or short-circuiting.

IEC 61034

(Measurement of smoke density of cables burning under defined conditions)

A plastic sample is burned under controlled conditions. In this way, the light transmission through the combustion gases which arise is measured.

Comparable tests are DIN VDE 0482-286-1 and -2, NFX 10702, BS 7622-2.

IEC 60754-1

(Test on halogen acid gases evolved during combustion of materials from cables)

A plastic sample is burned under controlled conditions. In this way, the smoke gases are measured for their halogen content.

Comparable tests are DIN VDE 0482-267-2-1 and EN 50267-2, NF C 20454, BS 6425-1.

IEC 60754-2

(Test on acidity of gases evolved during combustion of materials from cables)

A plastic sample is burned under controlled conditions. In this way, the pH-value and the conductivity of the smoke gases are measured.

A comparable test is DIN VDE 0276-604.

With the exception of the small fire test according to EN/IEC 60332-1, the cable is normally destroyed during the flame test. Although no short-circuiting or interruptions should arise, it is difficult to speak about defined electrical values such as operating capacity or characteristic impedance. In this case we are talking about either: current flowing or not. This may in reality be adequate for loudspeaker announcements or sprinkler systems. Control and safety technology using electronic interlocking is during or after a cable fire, if at all, hardly still sensible and feasible. Under these circumstances, the need to maintain fire testing standards according to EN/IEC 60331 (insulation integrity) and/or DIN 4102 part 12 (functional integrity) makes little sense for railway signalling cables for electronic interlocking.

Railway Main Line Cables

Construction Product Regulation

Since 01/07/2013, the “Construction Product Directive” (CPD) in the EU has been replaced by the “Construction Product Regulation” (CPR) and is thus valid law in all member states of the EU. The CPR and/or the building product directive (BPVo) affects all cables which are intended for permanent installation in a building. Products have to fulfil requirements in terms of behaviour and/or resistance in the case of fire.

CPR itself does not define any performance requirements regarding the affected products. The definition of safety requirements remains the responsibility of the national authorities.

CPR has introduced binding performance requirements (Declaration of Performance, DoP) and the corresponding CE-mark for labelling the products. The cable’s fire characteristics shall be marked in the future with a combination of different classes (The index “ca” stands for “cable”):

CPR classes are:	A_{ca} , $B1_{ca}$, $B2_{ca}$, C_{ca} , D_{ca} , E_{ca} , F_{ca}	(see table to the right)
Smoke classes are:	s1, s1a, s1b, s2, s3	(EN 50399/EN 61034-2)
Acidity classes are:	a1, a2, a3	(EN 60754-2)
Flaming droplets classes are:	d0, d1, d2	(EN 50399)

The CPR has no class or guideline for railway cables laid in exposed outdoor areas. These cables may continue to be designed, produced and installed as previously. For railway cables in tunnels or train stations, the relevant cable manufacturers associations recommend a classification according to the EU regulation (1303/2014), clause 4.2.2.4: “In case of fire, exposed cables shall have the characteristics of low flammability, low fire spread, low toxicity and low smoke density. These requirements are fulfilled when the cables fulfil as a minimum the requirements of classification $B2_{ca}$, s1a, a1, as per Commission Decision 2006/751/EC.”

Prysmian Group will observe these obligations and, as far as they do not satisfy existing cable designs, will provide cables and products to the market with the corresponding properties.

Class	Test method(s)	Classification criteria	Additional classification
A _{ca}	EN ISO 1716	PCS ≤ 2,0 MJ/kg and PCS ≤ 2,0 MJ/kg and	
B1 _{ca}	EN 50399	FS ≤ 1.75 m and THR1200s ≤ 10 MJ and Peak HRR ≤ 20 kW and FIGRA ≤ 120 Ws-1	Smoke production and Flaming droplets/particles and Acidity
	and EN 50265-2-1	H ≤ 425 mm	
B2 _{ca}	EN 50399	FS ≤ 1.5 m; and THR1200s ≤ 15 MJ; and Peak HRR ≤ 30 kW; and FIGRA ≤ 150 Ws-1	Smoke production and Flaming droplets/particles and Acidity
	and EN 50265-2-1	H ≤ 425 mm	
C _{ca}	EN 50399	FS ≤ 2.0 m; and THR1200s ≤ 30 MJ; and Peak HRR ≤ 60 kW; and FIGRA ≤ 300 Ws-	Smoke production and Flaming droplets/particles and Acidity
	and EN 50265-2-1	H ≤ 425 mm	
D _{ca}	EN 50399	THR1200s ≤ 70 MJ; and Peak HRR ≤ 400 kW; and FIGRA ≤ 1300 Ws-1	
	and EN 50265-2-1	H ≤ 425 mm	
E _{ca}	EN 50265-2-1	H ≤ 425 mm	
F _{ca}	no performance determined		

Table: Overview of the CPR classifications

Railway Main Line Cables

Transport and storage of cable drums

Even if cable and drum look very strong, there are certain rules to follow to avoid damage of the cable and an accompanying impairment of mechanical and electrical characteristics.

Transport and storage of cable drum

It is possible to store cable drums outdoors. When storage has occurred in heated rooms, a minimum 24-hour acclimatisation period must be observed before installation (possible condensation build-up in the cable!).

For outdoor storage the ground must be even and clean. Stones or bumps in the ground should be removed or smoothed out. Damage to the wound goods/cable should be avoided at all costs.

Cables should be secured against accidental rolling away. Under no circumstances should the drum flange of neighbouring cables touch any wound goods.

Cable drums should always be stored and transported standing on both flanges.

They should not be pushed along the ground standing on the flanges. It is possible that the strength of the cable drum would then no longer be guaranteed.

Observe the rolling direction. The arrow printed on the drum flange indicates the rolling direction so that the wound goods do not become loose.

Always uncoil the cable at a tangent, never over the flange, since the torsion thus resulting would damage the cable and laying would not be possible.

Cable ends

Finally it remains for us to point out the necessity of having faultless cable ends. Pressure-tight and impermeable cable ends are particularly essential for cables which are not longitudinally water-proof, as well as for cables which are insulated with paper, cellular-PE and foam-skin-PE. Carelessness in this area can lead to moisture penetration which is accompanied by a drastic deterioration in the electrical transmission rate. Power failures and expensive replacement work are the result.

Pressure-tight and impermeable cable ends can be achieved, for example, through the use of synthetic sealing resin or compressed air sealing stoppers.



Important physical characteristics

Temperature range

The temperature range of the cable is of great importance for both the user and fitter. After all the cable is meant to function equally well in cold and hot temperatures. It is particularly during the fitting process that powerful mechanical forces act on the cable. The plastic used serves as the limiting element for the possible temperature range. At overly warm temperatures the plastic becomes very soft and can change into a thermoplastic state (up to melting point), which causes irreversible changes in the cable.

At very cold temperatures, however, the material stiffens and becomes hard and inflexible. Here, too, irreparable damage can occur.

Tears in the sheath allow dampness and moisture in and impair the transmission rate. Details about the permissible temperature range during laying and use (following successful fitting) can be found in the information sheets of the cable manufacturer. Since the mechanical strain on the cable in its laid form is significantly less, the permissible temperature range is greater than the range valid for the installation period.

Bending radius

Regarding the bending radius we distinguish between multiple and single bending (shaping into the final position).

Multiple bending occurs mainly during the laying process. Cables are laid under tension around deflector rolls. The particular stress of multiple bending lies in the alternating stress on the materials, which can be stretched several times as well as compressed during the laying process.

To prevent permanent damage there are prescribed minimum bending radii of, for example, 10 x cable external diameter for multiple bending.

The stress on the material during final bending is not characterised by alternating stress. The cable is bent into form a final time and stays in this position for the duration of its use. The minimum bending radius in this case is, for example, 7.5 x cable external diameter. During final bending the cable can, therefore, be bent more tightly.

Exact minimum bending radii for specific cables can be found in the information sheets of the cable manufacturer.

Tension

During laying of the cable particular attention must be paid to the maximum possible tension. The cable is very quickly damaged by the use of too much force and must then be replaced. The maximum possible tension depends in the first place on the overall cross section and the tensile strength of the conducting materials used.

For cables with steel tape or copper wire spiral armouring it is the internal copper conductors alone which determine the maximum tension! The armouring has no influence on the maximum tension or can possibly reduce it through additional weight. For armouring with steel or steel profile wires, however, the tension is determined solely by the steel and steel profile wires.

Cable weight

The cable weight of larger cable dimensions can take weights of up to more than 10 t/km (without the reel!).

Railway Main Line Cables

Certifications and compliance

Certifications of Railway and Infrastructure Authorities

Being a very complex system with a high safety integrity level, railway products are subject to detailed requirements and strong supervision. Many railway infrastructure operators issued dedicated cable specifications which require homologation and frequent auditing. Prysmian Railway Cables are designed and produced according to a number of railway cables standards, like DB, SBB, ÖBB, SNCF, TCDD, ADIF/RENFE, RFI, RATP and many more in Europe and around the globe. High quality manufacturing processes, many decades of experience in cable design and engineering as well as intense testing procedures guarantee state-of-the-art cable products and satisfied customers worldwide.

REACH (Registration, Evaluation and Authorisation of Chemicals)

Adopted on December 18th, 2006, the Regulation of the European Parliament and the European Union Council, modernized the European legislation regarding chemical substances, and set up a unique integrated system of chemical substances in the European Union. Its objective is to improve the protection of the human health and of the environment, while maintaining the European chemical industry's competitiveness and strengthening its spirit of innovation. All Prysmian railway cables are REACH compliant.

RoHS (Restriction of the use of certain Hazardous Substances in Electrical and Electronic Equipment)

The RoHS directive aims at restricting the use of certain dangerous substances commonly used in electric and electronic equipment (EEE). Cables concerned by this directive are any cables rated below 250V, which function is the connection or the extension of an EEE to electrical outlet or the connection of two or more EEE to each other. All Prysmian railway cables are RoHS compliant.

Management Systems

- Quality Management System EN ISO 9001:2008
- Environmental Management System EN ISO 14001:2005
- Energy Management System EN ISO 50001:2011

Our responsibilities

Social Responsibility

Within the social dimension of its business, the Prysmian Group recognises its commitment and responsibility towards the persons who work as part of the Organisation, as well as those who form the local communities in the territories in which the Group is active. Accordingly, consistent with its values, Prysmian constantly seeks to ensure the personal and professional satisfaction of its human resources, and to communicate with and involve local populations, in order to generate value for these important categories of stakeholder.

Environmental responsibility

The Group's commitment to safeguarding the environment and conserving natural resources is expressed not only by the intrinsic characteristics of our products, but also by how our production systems are managed. In particular, the prevention and reduction of their environmental impact is achieved, for example, by the efficient use of natural resources, the optimisation of logistics flows and the responsible management of waste.

During 2015, HSE further consolidated its activities at various levels within the Group (corporate, country or geographical area, business unit, production unit), centralising activities and coordinating the work of the local HSE functions. Group policies for Health, Safety and Environment, as well as the related Operating Procedures and Technical Standards, have been adopted and applied at operating unit level. The HSE function, with support from the Group audit team, periodically checks the effectiveness and proper application of the HSE rules at local level.

The aspects monitored by HSE using indicators include compliance with health and safety at work standards, energy consumption, waste management, water usage and greenhouse gas emissions. In particular, with reference to the greenhouse gas emissions, the Group has begun to collect energy consumption data in order to track both "direct" emissions (deriving from production processes) and "indirect" emissions (deriving from the energy purchased). This system of monitoring and reporting enabled the Group to participate in 2015, once again, in the Carbon Disclosure Project (CDP), which seeks to contribute to the pursuit of the objectives agreed in the Kyoto Protocol regarding the global reduction of greenhouse gas emissions

Product responsibility

Quality and innovation are the hallmarks of Prysmian's approach, both in sectors where the level of technology, the ability to innovate constantly and the commitment to offering high value-added services together establish a differentiated competitive positioning, and in those sectors where products are more standardised, such as medium and low-voltage cables. The Group applies a customer-centric approach, reflecting an ability to anticipate and satisfy the needs of customers with the maximum possible attention.

Railway Main Line Cables

References

Prysmian Group has been supplying the railway industry for many decades. We supply all renowned European railway infrastructure companies, often as part of long-term master agreements. Many important projects have been completed in the recent years all around the world, even more are yet to come. There is always our office close to you.

The following excerpt of our success records shall give you an idea about our local and global presence.

North Europe

- Denmark: ERTMS Signalling Program, Electrification of Danish Railways, Renewal of Danish Rail Infrastructure,
- Copenhagen Metro and S-Bane, Aarhus Tram
- Finland: Länsi Metro, Helsinki Metro, Rail Safety Project, Electrification of Jyväskylä-Äänekoski Line
- Norway: LKAB Narvik-Kiruna Line, InterCity Project, GSM-R Network for the ERTMS Signalling Program
- Sweden: Renewal of Stockholm Metro
- Latvia: Modernization of LZD-infrastructure

Rest of the world

- Australia: QueenslandRail, conversion to axle counter detection technology
- Egypt: Cairo – Alexandria line
- Bulgaria: Plovdiv-Bourgas line
- Chile: Rancagua project
- Germany: Framework contract and development partner of Deutsche Bahn
- Israel: Ashkelon – Netivot line
- Canada: Toronto Transit Authority
- Croatia: Zagreb Central Station
- Malaysia: Thomson Line project
- Morocco: Casablanca – Tanger line
- Mexico: Metro Monterey
- Saudi Arabia: North-South-Rail project, Mecca Metro
- Switzerland: Framework contract with SBB
- Singapore: Singapore Metro Subaqua Cable
- Spain: Vandellos-Tarragona line, Madrid – Leon – Burgos high speed Line
- Turkey: Ankara-Konya high speed line, Eskisehir – Balıkesir line, Metro Istanbul, Metro Ankara
- USA: JFK Air Train, New York City Transit, Oakland Bay Area Rapid Transit



We are here for you

You are always welcome to contact us directly with technical questions or sales enquires.

Contact

Telephone: +45 60 39 26 69

E-mail

dk-ti-sales@prysmiangroup.com

Website

www.prysmiangroup.dk

Prysmian Denmark A/S

Roskildevej 22

2620 Albertslund

Denmark